



PARTS CATALOGUE

YZ250FY (5XCR) CANADA

YZ250F (5XCS) EUROPE

YZ250F (5XCT) JAPAN

YZ250FY (5XCU) OCEANIA, SOUTH AFRICA

YZ250FY/YZ250F
PARTS CATALOGUE
©2008 by Yamaha Motor Co., Ltd.
1st edition, June 2008
All rights reserved.
Any reprinting or unauthorized use
without the written permission of
Yamaha Motor Co., Ltd.
is expressly prohibited.
Printed in Japan.

FOREWORD

This Parts Catalogue is related to the parts for the model(s) on the cover page. When you are ordering replacement parts, please refer to this Parts Catalogue and quote both part numbers and part names correctly.

1. Modifications or additions which have been made after the issue of the Parts Catalogue will be announced in the Parts News.

It is advisable that you make the necessary corrections to the Parts Catalogue according to the Parts News.

2. Abbreviations

The following abbreviations are used in this Parts Catalogue.

“UR” Use specified parts number.

“UN” Use as many as needed.

“AP” Alternate Parts

“LM” Locally Made (Parts need to be ordered locally)

“F#” Frame No. (Applicable machine No.)

“O/S” Over Size

3. The number of components for assembly

- Parts, which are to be supplied in an assembly, are listed with a dot (.) in front of the part name as shown below.
- The numeral appearing to the right of each component part indicates the quantity of parts for each assembly unit.

PART NO.	DESCRIPTION	Q'TY	REMARKS
2F5-83310-60	FRONT FLASHER LIGHT ASSY	2	
115-83311-60	.BULB (6V-18W)	1	

4. Applicable colours of graphics are represented in the “REMARKS” as shown below.

PART NO.	DESCRIPTION	Q'TY	REMARKS
2N4-24110-00-X5	FUEL TANK COMP.	2	MXR
3J1-24240-10	.GRAPHIC, FUEL TANK	1	FOR MXR

5. Note that the illustrations for reference in finding parts numbers are not to be used for assembling. When assembling, please use the applicable service manual.

6. The asterisk (*) before a reference number indicates modified items after the first edition.

CONTENTS

ENGINE

CYLINDER	1
CRANKSHAFT & PISTON	3
VALVE	4
CAMSHAFT & CHAIN	6
WATER PUMP	7
RADIATOR & HOSE	8
OIL PUMP	9
OIL CLEANER	11
INTAKE	12
CARBURETOR	13
EXHAUST	17
EXHAUST 2	18
CRANKCASE	19
CRANKCASE COVER 1	20
STARTER	22
CLUTCH	23
TRANSMISSION	24
SHIFT CAM & FORK	26
SHIFT SHAFT	27

CHASSIS

FRAME	28
FENDER	30
SIDE COVER & OIL TANK	32
REAR ARM	34
REAR SUSPENSION	36
STEERING	38
FRONT FORK	39
FUEL TANK	42
SEAT	44
FRONT WHEEL	45
FRONT BRAKE CALIPER	46
REAR WHEEL	47
REAR BRAKE CALIPER	49
STEERING HANDLE & CABLE	50
FRONT MASTER CYLINDER	51
STAND & FOOTREST	52
REAR MASTER CYLINDER	53
GENERATOR	54
HANDLE SWITCH & LEVER	55
ELECTRICAL 1	56

ALTERNATE FOR CHASSIS	57
-----------------------------	----

INDEX

NUMERICAL INDEX	59
-----------------------	----

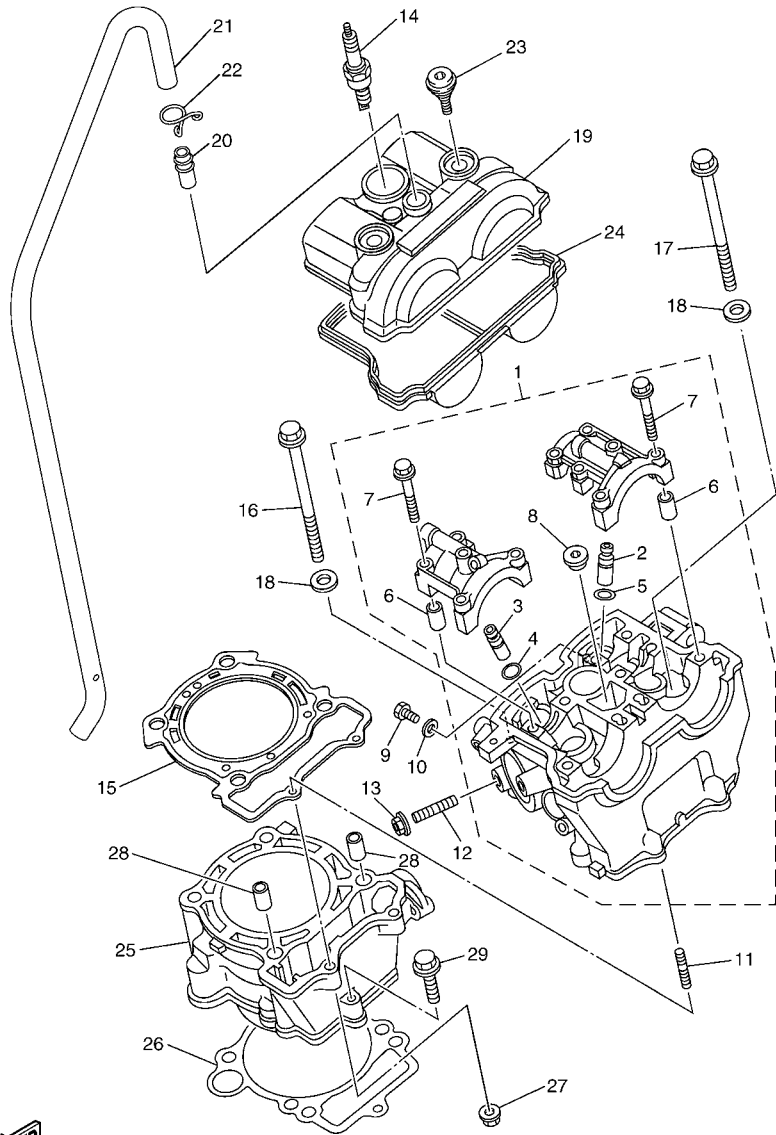

5XC100-F010

FIG. 1 CYLINDER

REF. NO.	PART NO.	DESCRIPTION	5XCR	5XCS	5XCT	5XCU	REMARKS
1	5XC-11102-20	CYLINDER HEAD ASSY	1	1	1	1	
2	5NL-11133-10	.GUIDE, VALVE 1	3	3	3	3	
3	5NL-11134-10	.GUIDE, VALVE 2	2	2	2	2	
4	93440-10153	.CIRCLIP	2	2	2	2	
5	93440-07149	.CIRCLIP	3	3	3	3	
6	91808-16023	.PIN, DOWEL	4	4	4	4	
7	90105-06027	.BOLT, FLANGE	10	10	10	10	
8	90340-12007	.PLUG, STRAIGHT SCREW	1	1	1	1	
9	95022-06010	BOLT, FLANGE	1	1	1	1	
10	90430-06014	GASKET	1	1	1	1	
11	90116-06038	BOLT, STUD	2	2	2	2	
12	95612-08620	BOLT, STUD	2	2	2	2	
13	95702-08500	NUT, WITH WASHER	2	2	2	2	
14	94701-00411	PLUG, SPARK (NGK R CR8E)	1	1		1	STD
	94703-00411	PLUG, SPARK (NGK R CR8E)			1		STD
	94701-00410	PLUG, SPARK (NGK R CR9E)	1	1		1	AP
	94703-00410	PLUG, SPARK (NGK R CR9E)			1		AP
15	5NL-11181-00	GASKET, CYLINDER HEAD 1	1	1	1	1	
16	90105-09004	BOLT, FLANGE	2	2	2	2	
17	90105-09002	BOLT, FLANGE	2	2	2	2	
18	90201-096J9	WASHER, PLATE	4	4	4	4	
19	5NL-11191-40	COVER, CYLINDER HEAD 1	1	1	1	1	
20	371-11167-01	PIPE, BREATHER 2	1	1	1	1	
21	5XC-11166-00	PIPE, BREATHER 1	1	1	1	1	
22	90467-140A4	CLIP	1	1	1	1	
23	5UM-1119E-00	BOLT, COVER HEAD	2	2	2	2	
24	5NL-11193-00	GASKET, HEAD COVER 1	1	1	1	1	

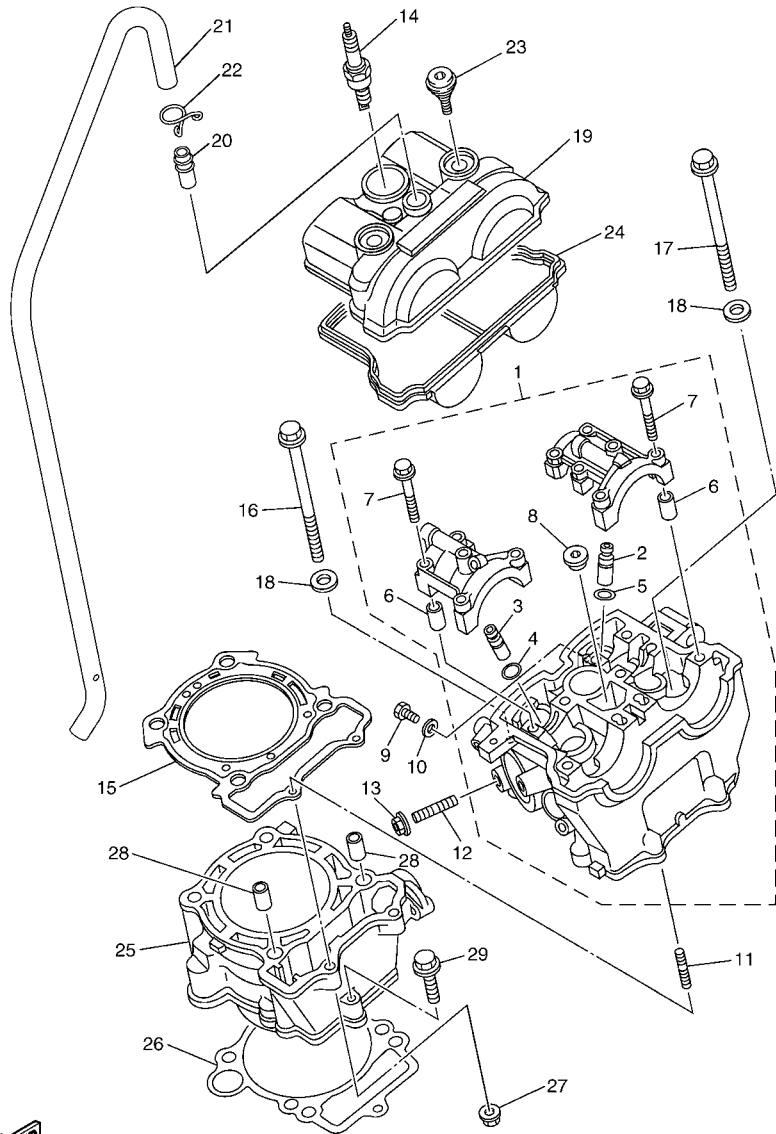

5XCG100-F010

FIG. 1 CYLINDER

REF. NO.	PART NO.	DESCRIPTION	5XCR	5XCS	5XCT	5XCU	REMARKS
25	5XC-11311-10	CYLINDER 1	1	1	1	1	
26	5NL-11351-00	GASKET, CYLINDER	1	1	1	1	
27	95702-06500	NUT, FLANGE	2	2	2	2	
28	93612-16254	PIN, DOWEL	2	2	2	2	
29	95022-06035	BOLT, FLANGE	1	1	1	1	

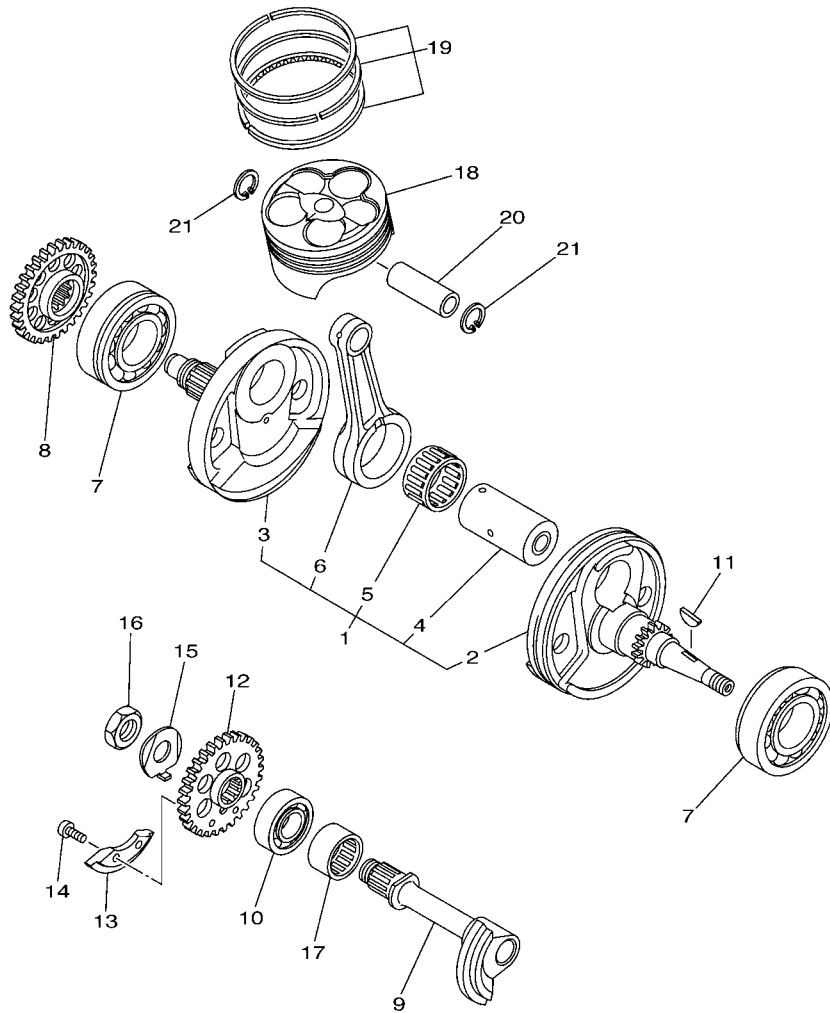

5XCL100-G020

FIG. 2 CRANKSHAFT & PISTON

REF. NO.	PART NO.	DESCRIPTION	5XCR	5XCS	5XCT	5XCU	REMARKS
1	5XC-11400-20	CRANKSHAFT ASSY	1	1	1	1	
2	5UL-11412-20	.CRANK 1	1	1	1	1	
3	5UL-11422-10	.CRANK 2	1	1	1	1	
4	5XC-11681-00	.PIN, CRANK 1	1	1	1	1	
5	93310-63238	.BEARING	1	1	1	1	
6	5XC-11651-00	.ROD, CONNECTING	1	1	1	1	
7	93306-20648	BEARING	2	2	2	2	
8	5NL-11536-10	GEAR, DRIVE	1	1	1	1	
9	5NL-11455-00	SHAFT 1	1	1	1	1	
10	93306-20335	BEARING	1	1	1	1	
11	90280-03006	KEY, WOODRUFF	1	1	1	1	
12	5NL-11531-00	GEAR, BALANCE WEIGHT	1	1	1	1	
13	5NL-11454-00	WEIGHT 1	1	1	1	1	
14	90149-06084	SCREW	2	2	2	2	
15	90215-14204	WASHER, LOCK	1	1	1	1	
16	90170-14171	NUT	1	1	1	1	
17	93311-32261	BEARING	1	1	1	1	
18	5XC-11631-00	PISTON (STD)	1	1	1	1	
19	5NL-11603-00	PISTON RING SET (STD)	1	1	1	1	
20	5NL-11633-00	PIN, PISTON	1	1	1	1	
21	93420-16086	CIRCLIP	2	2	2	2	

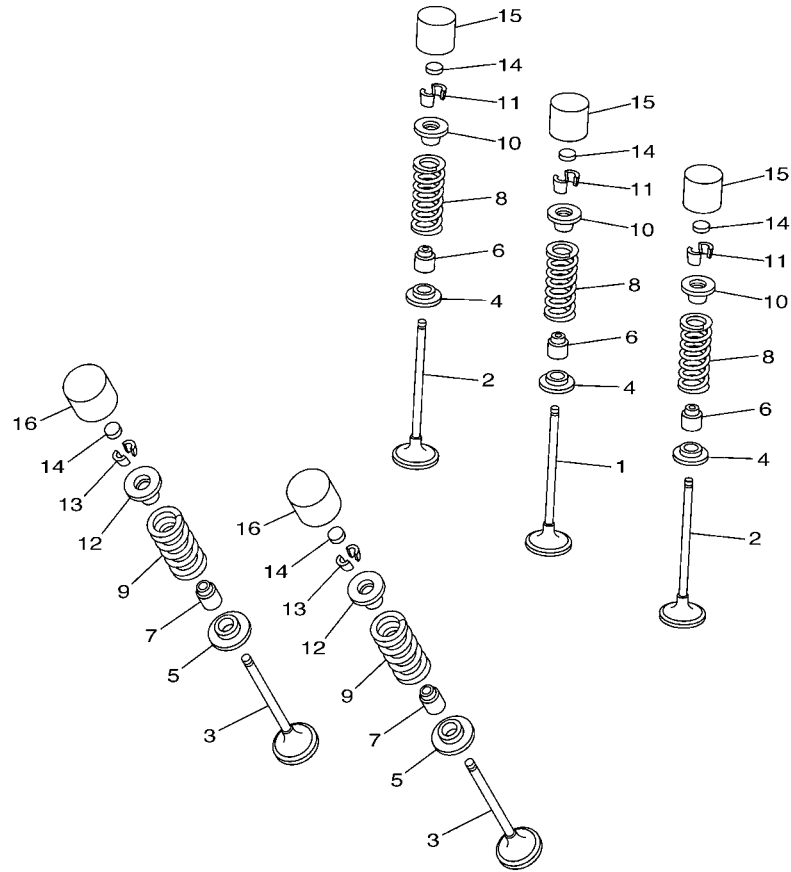

5NL1100-1030

FIG. 3 VALVE

REF. NO.	PART NO.	DESCRIPTION	5XCR	5XCS	5XCT	5XCU	REMARKS
1	5NL-12111-20	VALVE, INTAKE	1	1	1	1	
2	5NL-12112-20	VALVE, INTAKE 2	2	2	2	2	
3	5NL-12121-10	VALVE, EXHAUST	2	2	2	2	
4	5NL-12116-00	SEAT, VALVE SPRING	3	3	3	3	
5	3GM-12126-00	SEAT, VALVE SPRING 2	2	2	2	2	
6	4TV-12119-00	SEAL, VALVE STEM	3	3	3	3	
7	4SV-12119-00	SEAL, VALVE STEM	2	2	2	2	
8	5NL-12113-00	SPRING, VALVE INNER	3	3	3	3	
9	5NL-12114-00	SPRING, VALVE OUTER	2	2	2	2	
10	1HX-12117-00	RETAINER, VALVE SPRING	3	3	3	3	
11	1HX-12118-00	COTTER, VALVE	6	6	6	6	
12	1WG-12117-00	RETAINER, VALVE SPRING	2	2	2	2	
13	1WG-12118-00	COTTER, VALVE	4	4	4	4	
14	1HX-12168-00	PAD, ADJUSTING 2 (1.20)	5	5	5	5	UR
	1HX-12168-20	PAD, ADJUSTING 2 (1.25)	5	5	5	5	UR
	1HX-12168-40	PAD, ADJUSTING 2 (1.30)	5	5	5	5	UR
	1HX-12168-60	PAD, ADJUSTING 2 (1.35)	5	5	5	5	UR
	1HX-12168-80	PAD, ADJUSTING 2 (1.40)	5	5	5	5	UR
	1HX-12168-A0	PAD, ADJUSTING 2 (1.45)	5	5	5	5	UR
	1HX-12168-F0	PAD, ADJUSTING 2 (1.50)	5	5	5	5	UR
	1HX-12168-H1	PAD, ADJUSTING 2 (1.55)	5	5	5	5	UR
	1HX-12168-K1	PAD, ADJUSTING 2 (1.60)	5	5	5	5	UR
	1HX-12168-M1	PAD, ADJUSTING 2 (1.65)	5	5	5	5	UR
	1HX-12168-R1	PAD, ADJUSTING 2 (1.70)	5	5	5	5	UR
	1HX-12168-U1	PAD, ADJUSTING 2 (1.75)	5	5	5	5	UR
	1HX-12168-W1	PAD, ADJUSTING 2 (1.80)	5	5	5	5	UR
	1HX-12168-Y1	PAD, ADJUSTING 2 (1.85)	5	5	5	5	UR

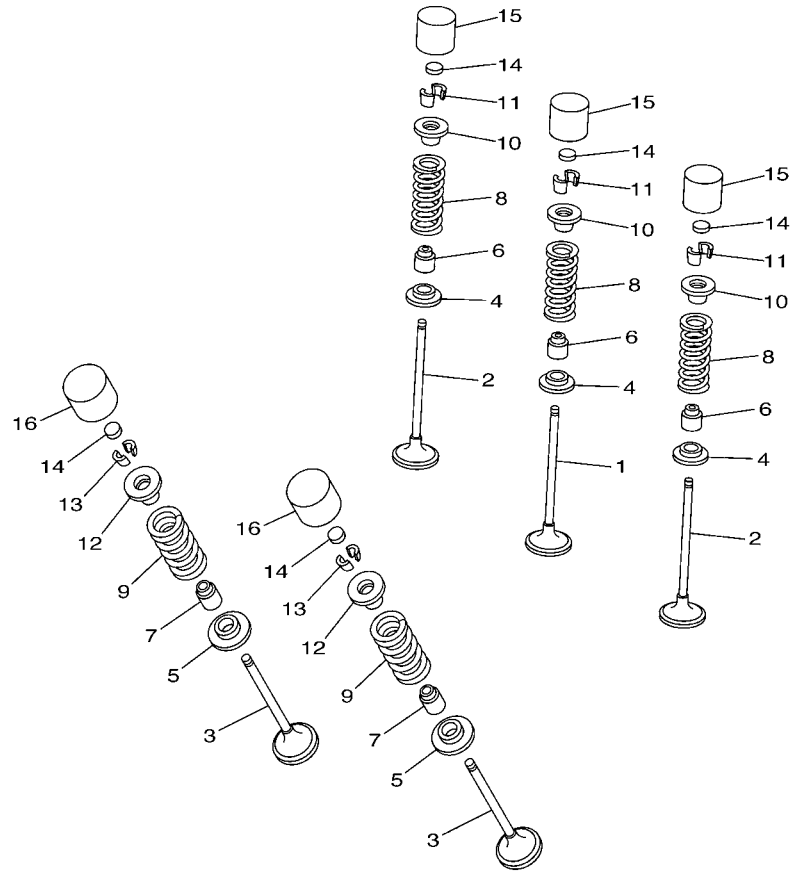

5NL1100-1030

FIG. 3 VALVE

REF. NO.	PART NO.	DESCRIPTION	5XCR	5XCS	5XCT	5XCU	REMARKS
14	1HX-12169-11	PAD, ADJUSTING 2 (1.90)	5	5	5	5	UR
	1HX-12169-31	PAD, ADJUSTING 2 (1.95)	5	5	5	5	UR
	1HX-12169-50	PAD, ADJUSTING 2 (2.00)	5	5	5	5	UR
	1HX-12169-70	PAD, ADJUSTING 2 (2.05)	5	5	5	5	UR
	1HX-12169-90	PAD, ADJUSTING 2 (2.10)	5	5	5	5	UR
	1HX-12169-E0	PAD, ADJUSTING 2 (2.15)	5	5	5	5	UR
	1HX-12169-G0	PAD, ADJUSTING 2 (2.20)	5	5	5	5	UR
	1HX-12169-J0	PAD, ADJUSTING 2 (2.25)	5	5	5	5	UR
	1HX-12169-L0	PAD, ADJUSTING 2 (2.30)	5	5	5	5	UR
	1HX-12169-N0	PAD, ADJUSTING 2 (2.35)	5	5	5	5	UR
	1HX-12169-T0	PAD, ADJUSTING 2 (2.40)	5	5	5	5	UR
15	3LN-12153-10	LIFTER, VALVE	3	3	3	3	YELLOW
16	3FV-12153-10	LIFTER, VALVE	2	2	2	2	YELLOW

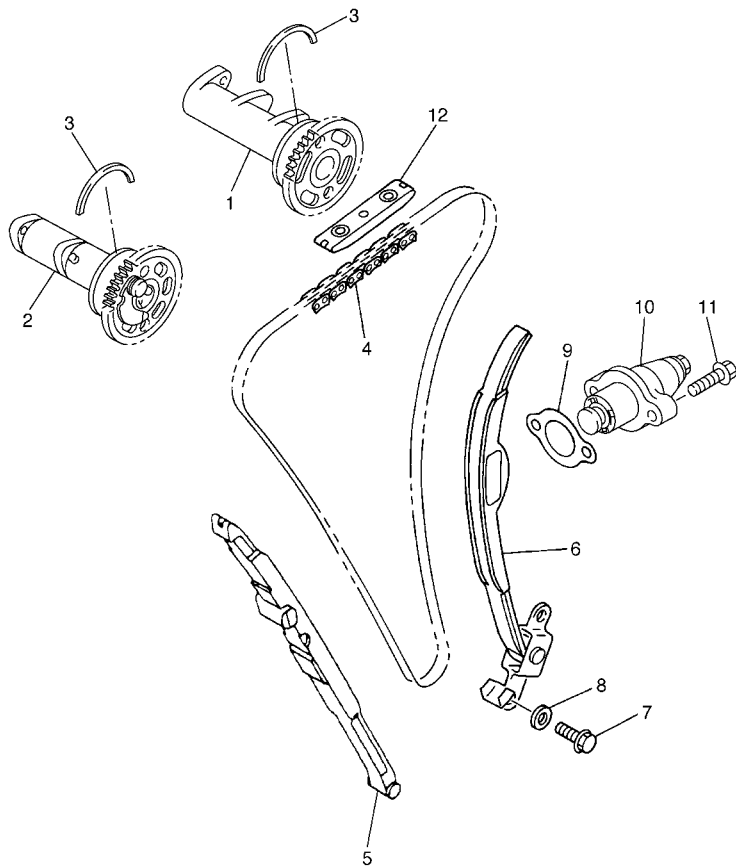
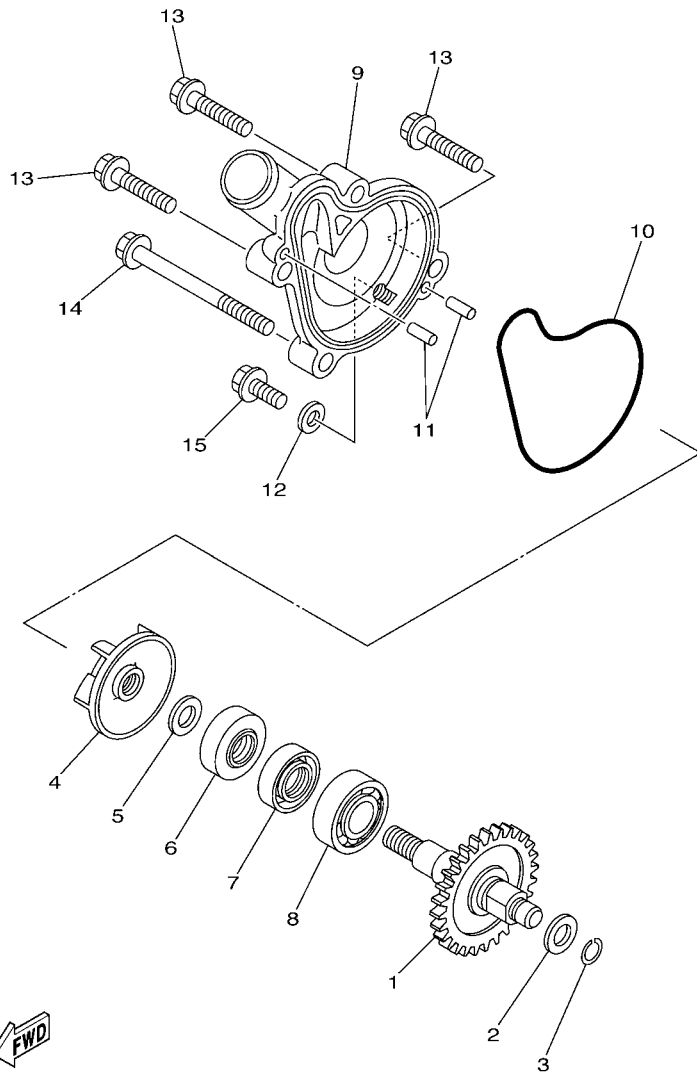

FIG. 4 CAMSHAFT & CHAIN

REF. NO.	PART NO.	DESCRIPTION	5XCR	5XCS	5XCT	5XCU	REMARKS
1	5UL-12170-10	CAMSHAFT ASSY 1	1	1	1	1	
2	5UL-12180-10	CAMSHAFT ASSY 2	1	1	1	1	
3	93440-41178	CIRCLIP	2	2	2	2	
4	94591-53114	CHAIN	1	1	1	1	
5	5NL-12251-10	DAMPER, CHAIN 1	1	1	1	1	
6	5NL-12252-00	DAMPER, CHAIN 2	1	1	1	1	
7	97022-06016	BOLT	2	2	2	2	
8	92902-06600	WASHER, PLATE	2	2	2	2	
9	4FM-12213-00	GASKET, TENSIONER CASE	1	1	1	1	
10	5TA-12210-20	TENSIONER ASSY, CAM CHAIN	1	1	1	1	
11	95022-06025	BOLT, FLANGE	2	2	2	2	
12	5BE-12241-00	GUIDE, STOPPER 2	1	1	1	1	



5XC9100-E040



5NL1100-1050

FIG. 5 WATER PUMP

REF. NO.	PART NO.	DESCRIPTION	5XCR	5XCS	5XCT	5XCU	REMARKS
1	5XC-12459-00	GEAR, IMPELLER SHAFT	1	1	1	1	
2	90201-08512	WASHER, PLATE	1	1	1	1	
3	93440-07182	CIRCLIP	1	1	1	1	
4	5DH-12451-00	IMPELLER, WATER PUMP	1	1	1	1	
5	90201-08512	WASHER, PLATE	1	1	1	1	
6	93109-11073	OIL SEAL	1	1	1	1	
7	93102-12106	OIL SEAL (SD 12-22-5 HS)	1	1	1	1	
8	93306-00105	BEARING	1	1	1	1	
9	5NL-12422-10	COVER, HOUSING	1	1	1	1	
10	5NL-12439-00	O-RING	1	1	1	1	
11	93604-10011	PIN, DOWEL	2	2	2	2	
12	90430-06014	GASKET	1	1	1	1	
13	95022-06025	BOLT, FLANGE	3	3	3	3	
14	95022-06065	BOLT, FLANGE	1	1	1	1	
15	95022-06012	BOLT, FLANGE	1	1	1	1	

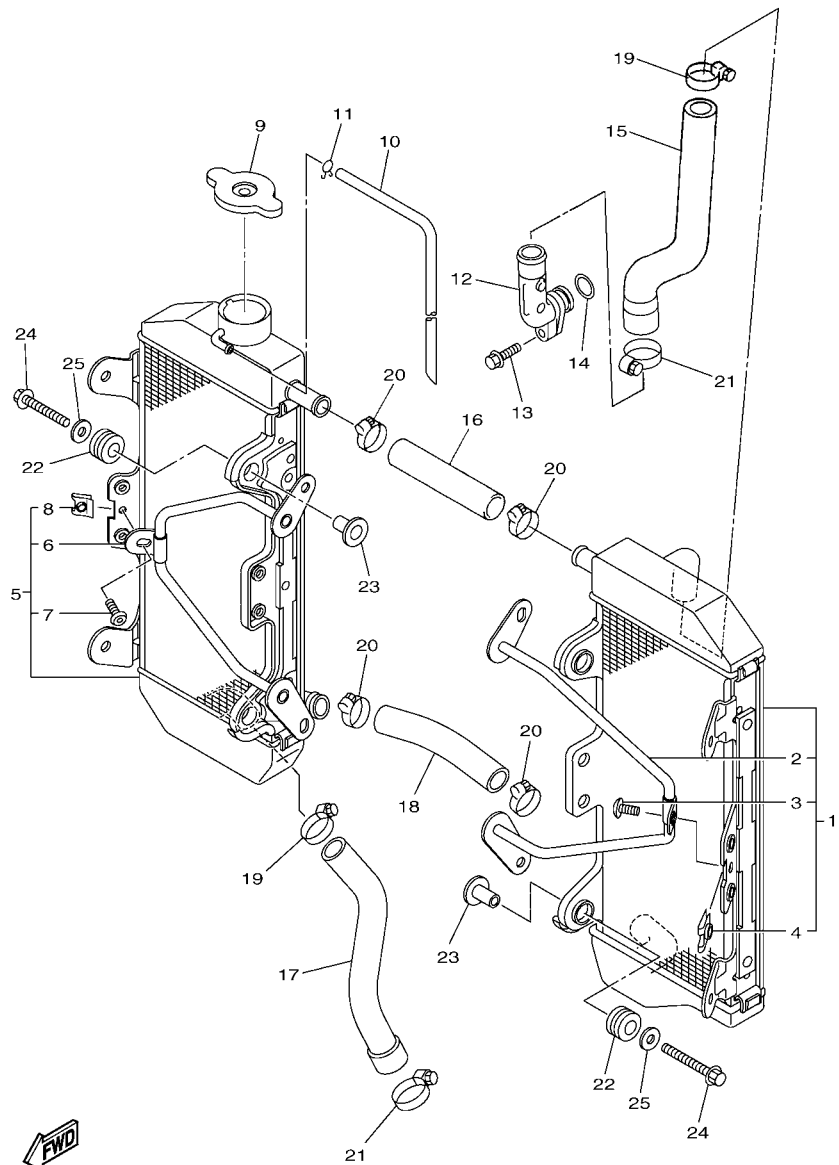

5XCG100-F060

FIG. 6 RADIATOR & HOSE

REF. NO.	PART NO.	DESCRIPTION	5XCR	5XCS	5XCT	5XCU	REMARKS
1	5XC-1240A-G0	RADIATOR ASSY	1	1	1	1	
2	2S2-12464-70	.STAY, RADIATOR	1	1	1	1	
3	92012-06010	.BOLT, BUTTON HEAD	3	3	3	3	
4	90183-060A6	.NUT, SPRING	1	1	1	1	
5	5XC-12461-G0	RADIATOR ASSY	1	1	1	1	
6	2S2-12464-70	.STAY, RADIATOR	1	1	1	1	
7	92012-06010	.BOLT, BUTTON HEAD	3	3	3	3	
8	90183-060A6	.NUT, SPRING	1	1	1	1	
9	22W-12462-00	CAP, RADIATOR	1	1	1	1	
10	91A20-05065	TUBE, FLEXIBLE VINYL	1	1	1	1	
11	90467-090A2	CLIP	1	1	1	1	
12	5XC-12481-G0	PIPE 1	1	1	1	1	
13	91312-06020	BOLT	1	1	1	1	
14	93210-16275	O-RING	1	1	1	1	
15	5XC-12576-G0	HOSE 1	1	1	1	1	
16	1C3-12482-00	PIPE 2	1	1	1	1	
17	5XC-12578-G0	HOSE 3	1	1	1	1	
18	5XC-12579-G0	HOSE 4	1	1	1	1	
19	90450-25001	HOSE CLAMP ASSY	2	2	2	2	
20	90450-22001	HOSE CLAMP ASSY	4	4	4	4	
21	90450-32003	HOSE CLAMP ASSY	2	2	2	2	
22	90480-15528	GROMMET	4	4	4	4	
23	90387-06065	COLLAR	4	4	4	4	
24	90105-06111	BOLT, FLANGE	4	4	4	4	
25	90201-06571	WASHER, PLATE	4	4	4	4	

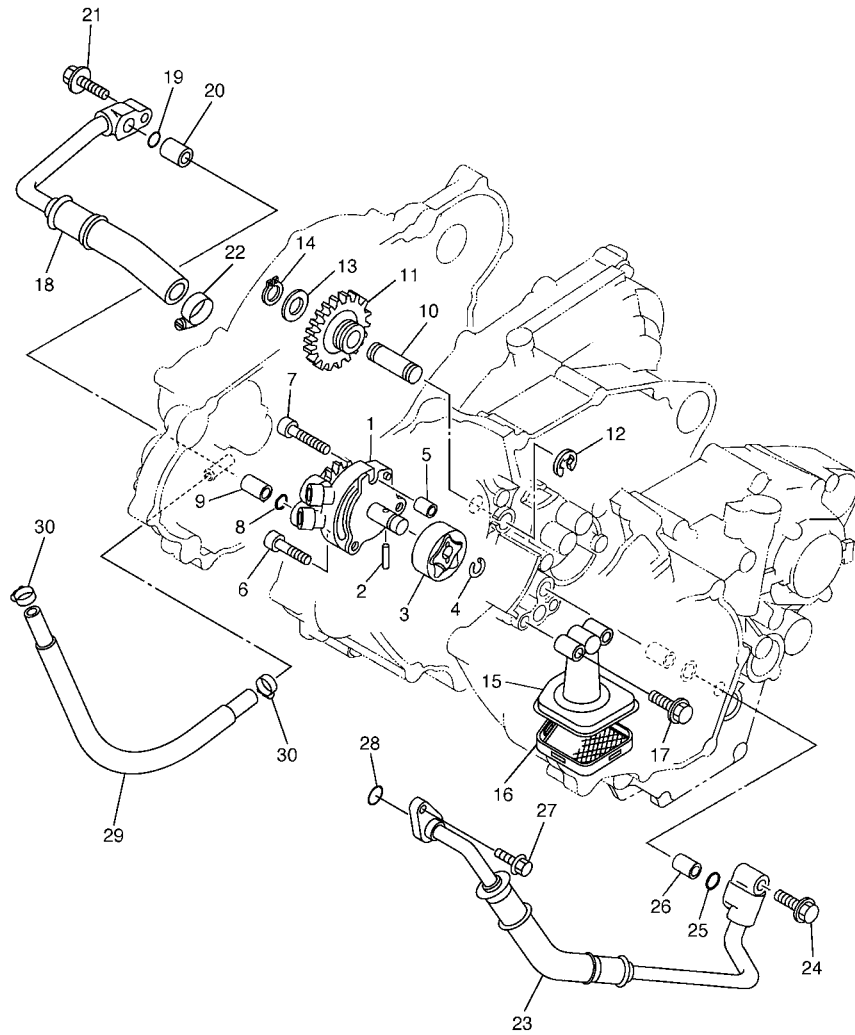

5XC9100-E070

FIG. 7 OIL PUMP

REF. NO.	PART NO.	DESCRIPTION	5XCR	5XCS	5XCT	5XCU	REMARKS
1	5SG-13300-01	OIL PUMP ASSY	1	1	1	1	
2	93603-16219	PIN, DOWEL	1	1	1	1	
3	5NL-13320-00	ROTOR ASSY 2	1	1	1	1	
4	93440-10153	CIRCLIP	1	1	1	1	
5	99530-08012	PIN, DOWEL	1	1	1	1	
6	91312-06025	BOLT	2	2	2	2	
7	91317-06030	BOLT	1	1	1	1	
8	93210-10197	O-RING	1	1	1	1	
9	99530-10114	PIN, DOWEL	1	1	1	1	
10	5BE-13342-00	SHAFT, IDLE GEAR	1	1	1	1	
11	5NL-13341-00	GEAR, OIL PUMP IDLE	1	1	1	1	
12	99001-08600	CIRCLIP	1	1	1	1	
13	90201-12166	WASHER, PLATE	1	1	1	1	
14	99009-12400	CIRCLIP	1	1	1	1	
15	5XC-13412-00	HOUSING, STRAINER	1	1	1	1	
16	5NL-13411-00	STRAINER, OIL	1	1	1	1	
17	95022-06025	BOLT, FLANGE	2	2	2	2	
18	5XC-13464-30	HOSE, OIL 1	1	1	1	1	
19	93210-10197	O-RING	1	1	1	1	
20	99530-10114	PIN, DOWEL	1	1	1	1	
21	95022-06025	BOLT, FLANGE	1	1	1	1	
22	90450-22001	HOSE CLAMP ASSY	1	1	1	1	
23	5XC-13465-30	HOSE, OIL 2	1	1	1	1	
24	95022-06025	BOLT, FLANGE	1	1	1	1	
25	93210-10197	O-RING	1	1	1	1	
26	99530-10114	PIN, DOWEL	1	1	1	1	
27	95022-06016	BOLT, FLANGE	1	1	1	1	



5XCG100-F080

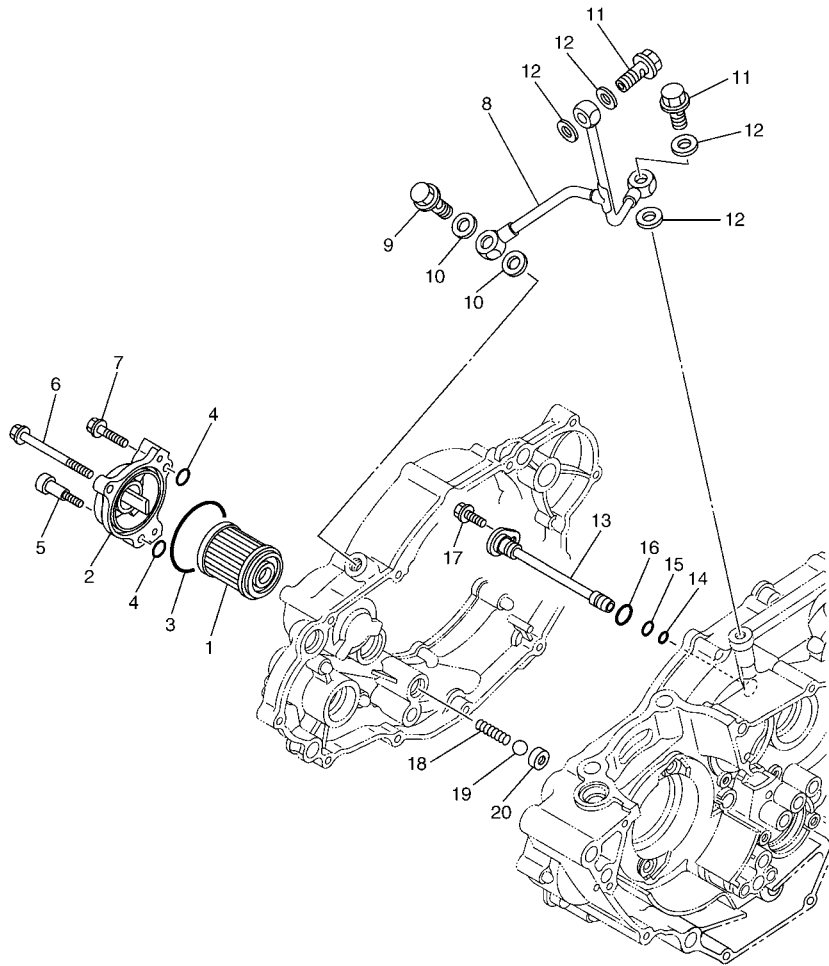

FIG. 8 OIL CLEANER

REF. NO.	PART NO.	DESCRIPTION	5XCR	5XCS	5XCT	5XCU	REMARKS
1	5D3-13440-00	ELEMENT ASSY, OIL CLEANER	1	1	1	1	
2	5BE-13447-20	COVER, OIL ELEMENT	1	1	1	1	
3	93210-47675	O-RING	1	1	1	1	
4	93210-07135	O-RING	3	3	3	3	
5	90110-06228	BOLT, HEXAGON SOCKET HEAD	1	1	1	1	
6	91312-06065	BOLT	1	1	1	1	
7	91312-06025	BOLT	1	1	1	1	
8	5NL-13161-20	PIPE, DELIVERY 1	1	1	1	1	
9	90401-10015	BOLT, UNION	1	1	1	1	
10	90430-10188	GASKET	2	2	2	2	
11	90401-08006	BOLT, UNION	2	2	2	2	
12	90430-08119	GASKET	4	4	4	4	
13	5NL-13171-00	PIPE, DELIVERY 2	1	1	1	1	
14	93210-07003	O-RING	1	1	1	1	
15	93210-09008	O-RING	1	1	1	1	
16	93210-12759	O-RING	1	1	1	1	
17	95022-06012	BOLT, FLANGE	1	1	1	1	
18	90501-043E0	SPRING, COMPRESSION	1	1	1	1	
19	93503-08007	BALL	1	1	1	1	
20	583-13113-00	SEAT, CHECK BALL	1	1	1	1	

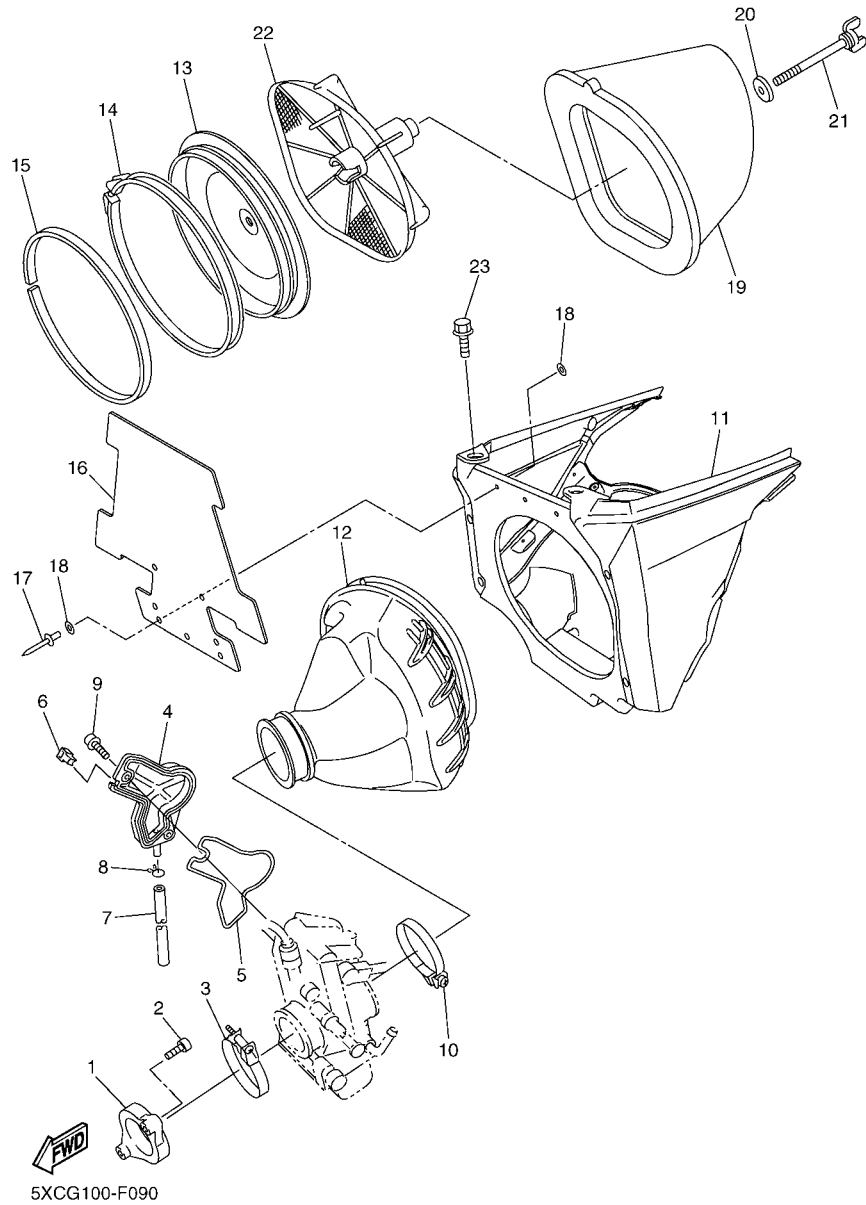
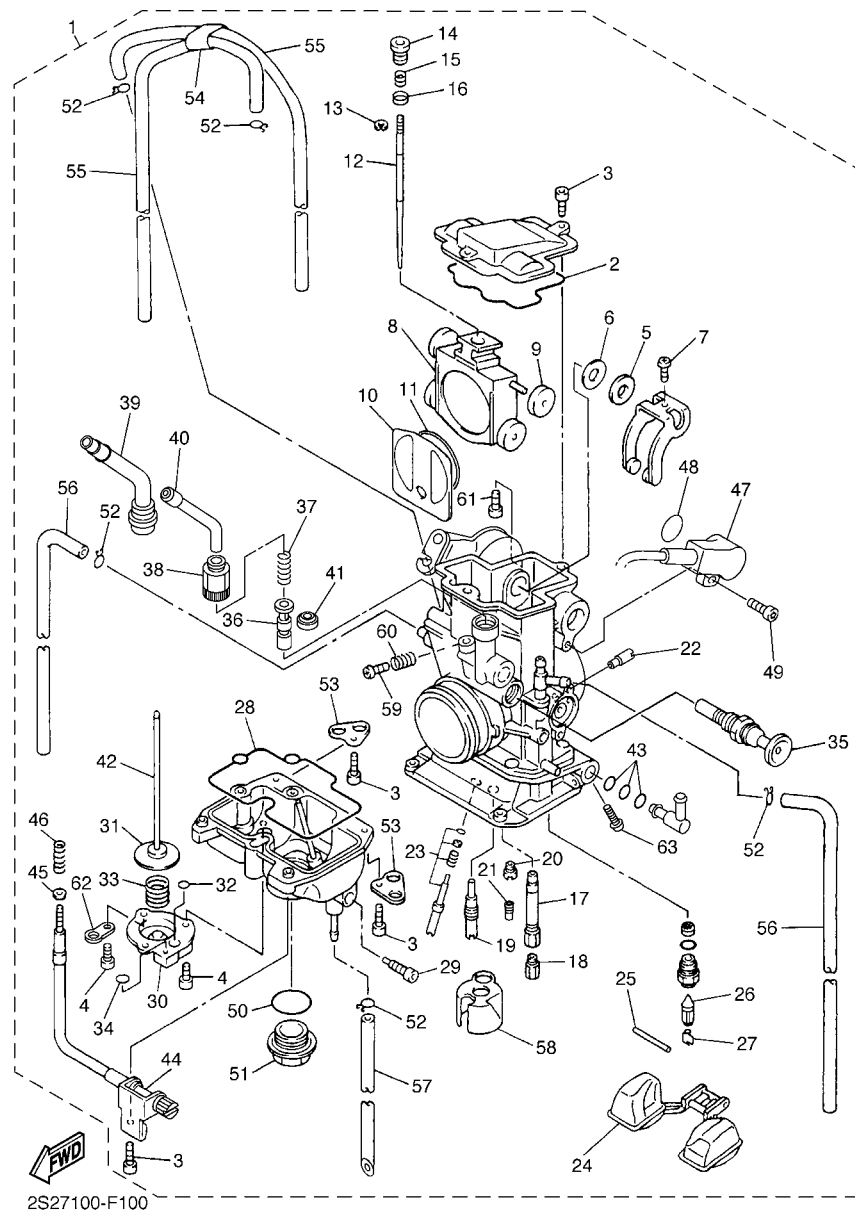

FIG. 9 INTAKE

REF. NO.	PART NO.	DESCRIPTION	5XCR	5XCS	5XCT	5XCU	REMARKS
1	5XC-13597-30	JOINT, CARBURETOR 3	1	1	1	1	
2	91312-06025	BOLT	2	2	2	2	
3	90450-57010	HOSE CLAMP ASSY	1	1	1	1	
4	5TA-14293-00	COVER 1	1	1	1	1	
5	5TA-14227-00	GASKET	1	1	1	1	
6	5TA-14239-00	SEAL	1	1	1	1	
7	5TA-14987-00	HOSE	1	1	1	1	
8	3TJ-14137-40	CLIP	1	1	1	1	
9	90110-05038	BOLT, HEXAGON SOCKET HEAD	2	2	2	2	
10	90450-61002	HOSE CLAMP ASSY	1	1	1	1	
11	2S2-14401-70	AIR CLEANER CASE ASSY	1	1	1	1	
12	5XC-14453-R0	JOINT, AIR CLEANER 1	1	1	1	1	
13	5NY-14459-00	HOLDER, GUIDE	1	1	1	1	
14	5NY-14455-20	BAND	1	1	1	1	
15	5NY-14442-00	SPACER	1	1	1	1	
16	5XC-14417-90	COVER 1	1	1	1	1	
17	90267-32070	RIVET, BLIND	3	3	3	3	
18	90201-03313	WASHER, PLATE	6	6	6	6	
19	4XM-14451-00	ELEMENT, AIR CLEANER	1	1	1	1	
20	90209-06096	WASHER	1	1	1	1	
21	90122-06005	BOLT, WING	1	1	1	1	
22	5BE-14458-00	GUIDE	1	1	1	1	
23	90109-06245	BOLT	2	2	2	2	



2S27100-F100

FIG. 10 CARBURETOR

REF. NO.	PART NO.	DESCRIPTION	5XCR	5XCS	5XCT	5XCU	REMARKS
1	5XC-14101-R0	CARBURETOR ASSY 1	1				
	5XC-14101-S0	CARBURETOR ASSY 1		1	1	1	
2	5JG-14959-00	.GASKET	1	1	1	1	
3	91316-04012	.BOLT	6	6	6	6	
4	688-14592-00	.SCREW	3	3	3	3	
5	90202-08045	.WASHER, PLATE	1	1	1	1	
6	5JG-14951-00	.WASHER	1	1	1	1	
7	5JG-14522-00	.SCREW, ADJUST	1	1	1	1	
8	2S2-14388-00	.VALVE, VACUUM CONTROL	1	1	1	1	
9	3TJ-14267-40	.ROLLER	1	1	1	1	
10	5JG-14546-01	.VALVE, NEEDLE	1	1	1	1	
11	4FN-14997-00	.SEAL	1	1	1	1	
12	5TA-14916-KR	.NEEDLE (#NHKR)	1				STD
	5TA-14916-LR	.NEEDLE (#NFLR)		1	1	1	STD
	5TA-14916-LN	.NEEDLE (#NFLN)		1	1	1	AP
	5TA-14916-LP	.NEEDLE (#NFLP)		1	1	1	AP
	5TA-14916-L1	.NEEDLE (#NFLQ)		1	1	1	AP
	5TA-14916-LS	.NEEDLE (#NFLS)		1	1	1	AP
	5TA-14916-LT	.NEEDLE (#NFLT)		1	1	1	AP
	5TA-14916-LU	.NEEDLE (#NFLU)		1	1	1	AP
	5TA-14916-PN	.NEEDLE (#NFPN)		1	1	1	AP
	5TA-14916-PP	.NEEDLE (#NFPP)		1	1	1	AP
	5TA-14916-P1	.NEEDLE (#NFPPQ)		1	1	1	AP
	5TA-14916-PR	.NEEDLE (#NFPR)		1	1	1	AP
	5TA-14916-PS	.NEEDLE (#NFPS)		1	1	1	AP
	5TA-14916-PT	.NEEDLE (#NFPT)		1	1	1	AP
	5TA-14916-PU	.NEEDLE (#NFPU)		1	1	1	AP

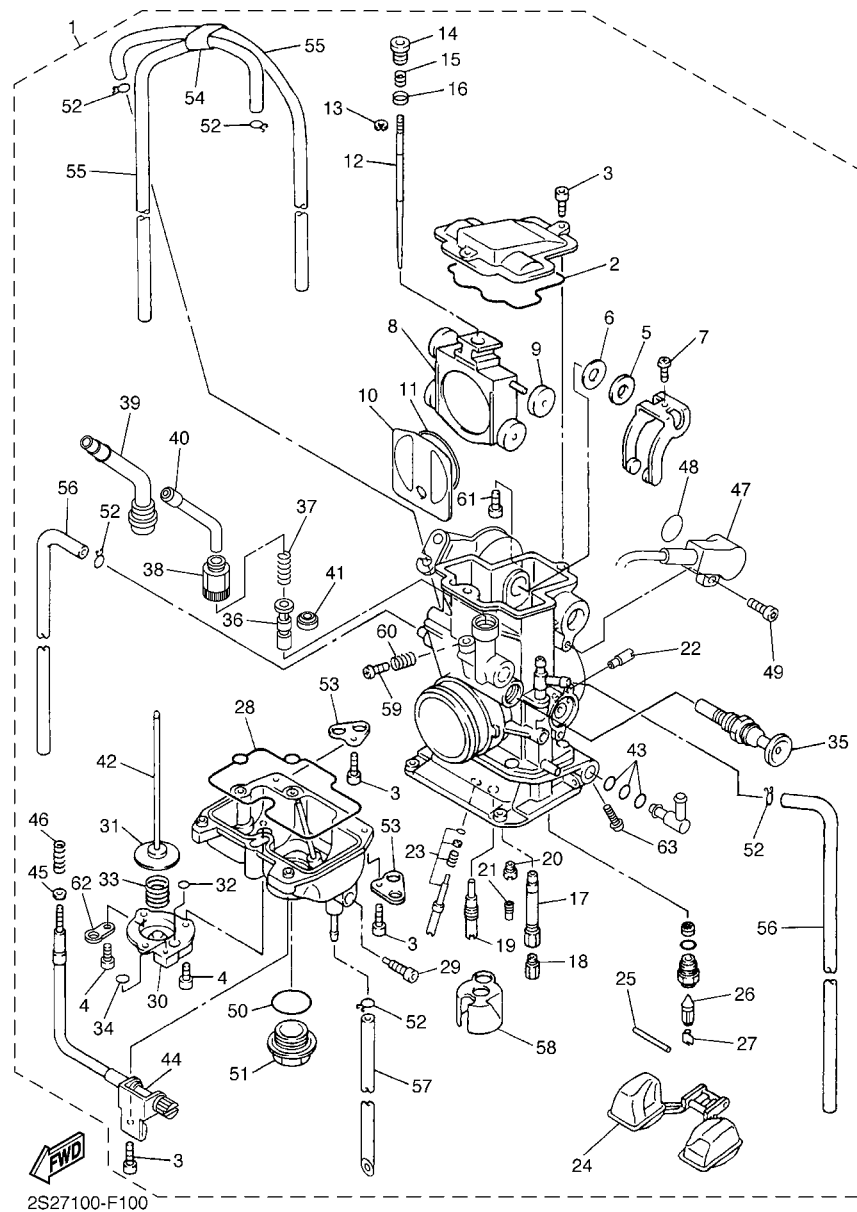

2S27100-F100

FIG. 10 CARBURETOR

REF. NO.	PART NO.	DESCRIPTION	5XCR	5XCS	5XCT	5XCU	REMARKS
13	3TJ-14159-40	.CLIP	1	1	1	1	
14	5JG-14521-00	.SCREW, ADJUST	1	1	1	1	
15	5JG-14275-00	.SPRING	1	1	1	1	
16	5JG-14264-00	.COLLAR	1	1	1	1	
17	5XC-14947-00	.JET, NEEDLE	1	1	1	1	
18	4MX-14943-93	.JET, MAIN (#178)	1	1	1	1	STD
	4MX-14943-91	.JET, MAIN (#168)	1	1	1	1	AP
	4MX-14943-41	.JET, MAIN (#170)	1	1	1	1	AP
	4MX-14943-92	.JET, MAIN (#172)	1	1	1	1	AP
	4MX-14943-42	.JET, MAIN (#175)	1	1	1	1	AP
	4MX-14943-43	.JET, MAIN (#180)	1	1	1	1	AP
	4MX-14943-94	.JET, MAIN (#182)	1	1	1	1	AP
	4MX-14943-44	.JET, MAIN (#185)	1	1	1	1	AP
	4MX-14943-95	.JET, MAIN (#188)	1	1	1	1	AP
19	4MX-14948-04	.JET, SLOW (#42)	1	1	1	1	STD
	4MX-14948-05	.JET, SLOW (#45)	1	1	1	1	STD
	4MX-14948-02	.JET, SLOW (#38)	1				AP
	4MX-14948-03	.JET, SLOW (#40)	1	1	1	1	AP
	4MX-14948-06	.JET, SLOW (#48)	1	1	1	1	AP
20	3TJ-1494F-16	.JET (#72)	1	1	1	1	STD
	3TJ-1494F-13	.JET (#65)	1	1	1	1	AP
	3TJ-1494F-14	.JET (#68)	1	1	1	1	AP
	3TJ-1494F-15	.JET (#70)	1	1	1	1	AP
	3TJ-1494F-17	.JET (#75)	1	1	1	1	AP
	3TJ-1494F-18	.JET (#78)	1	1	1	1	AP
	3TJ-1494F-19	.JET (#80)	1	1	1	1	AP
21	4JT-1494F-15	.JET (#70)	1	1	1	1	STD

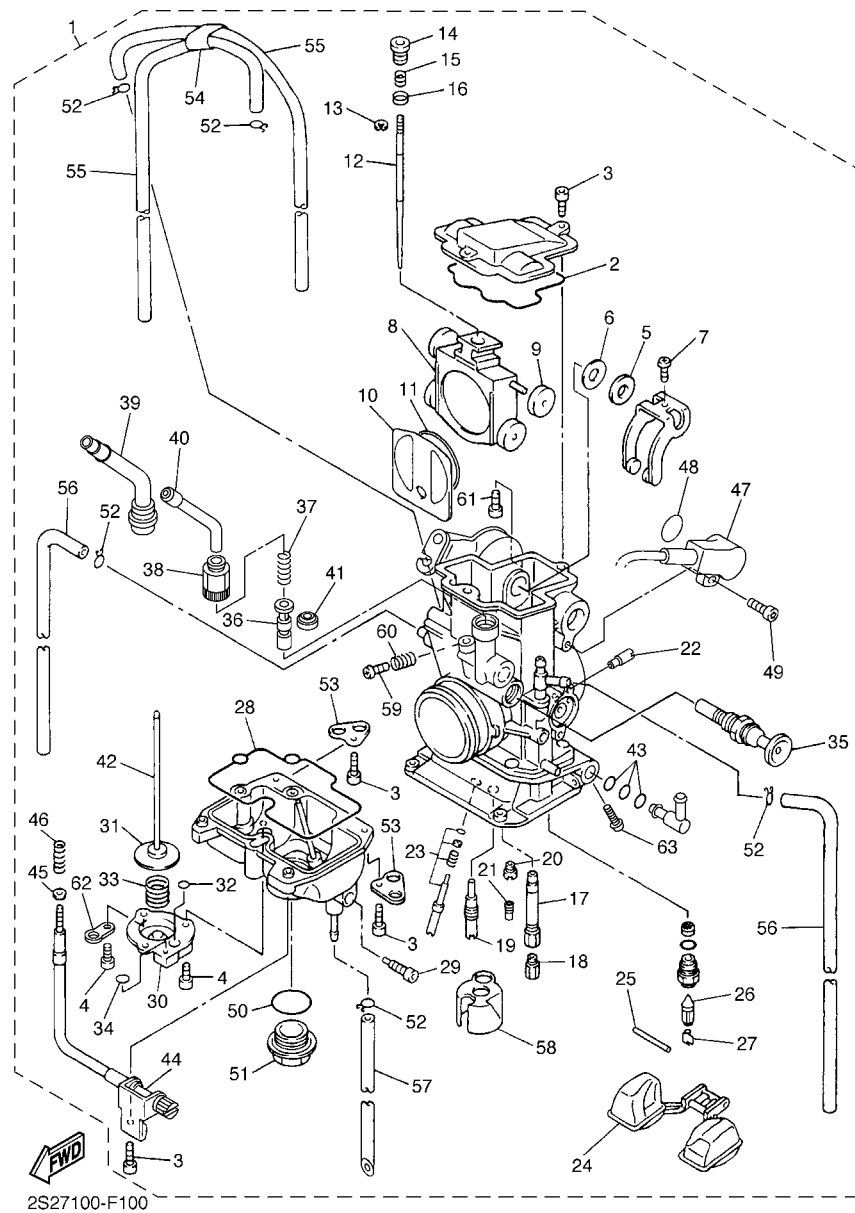

2S27100-F100

FIG. 10 CARBURETOR

REF. NO.	PART NO.	DESCRIPTION	5XCR	5XCS	5XCT	5XCU	REMARKS
21	4JT-1494F-03	.JET (#40)	1	1	1	1	AP
	4JT-1494F-07	.JET (#50)	1	1	1	1	AP
	4JT-1494F-11	.JET (#60)	1	1	1	1	AP
	4JT-1494F-19	.JET (#80)	1	1	1	1	AP
	4JT-1494F-23	.JET (#90)	1	1	1	1	AP
	4JT-1494F-27	.JET(#100)	1	1	1	1	AP
22	5TA-14943-28	.JET, MAIN (#105)	1	1	1	1	
23	5NL-14105-00	.PILOT SCREW SET	1	1	1	1	
24	4SR-14985-00	.FLOAT	1	1	1	1	
25	676-14548-00	.PIN, FLOAT ARM	1	1	1	1	
26	4MX-14392-00	.VALVE, NEEDLE	1	1	1	1	
27	633-14159-00	.CLIP	1	1	1	1	
28	5JG-14984-00	.GASKET, FLOAT CHAMBER	1	1	1	1	
29	3TJ-14191-40	.PLUG, DRAIN	1	1	1	1	
30	3TJ-14293-40	.COVER 1	1	1	1	1	
31	5JG-14940-76	.DIAPHRAGM ASSY	1	1	1	1	STD
	5JG-14940-16	.DIAPHRAGM ASSY	1	1	1	1	AP
	5JG-14940-17	.DIAPHRAGM ASSY	1	1	1	1	AP
	5JG-14940-18	.DIAPHRAGM ASSY	1	1	1	1	AP
32	3TJ-14536-40	.GASKET	1	1	1	1	
33	3TJ-14933-40	.SPRING, DIAPHRAGM	1	1	1	1	
34	6H4-14561-00	.O-RING	1	1	1	1	
35	5XC-14171-00	.PLUNGER, STARTER	1	1	1	1	
36	5TA-14371-00	.PLUNGER, STARTER	1	1	1	1	
37	5TA-14335-00	.SPRING, PLUNGER	1	1	1	1	
38	5TA-14991-00	.SCREW	1	1	1	1	
39	2S2-14374-00	.CAP, PLUNGER	1	1	1	1	

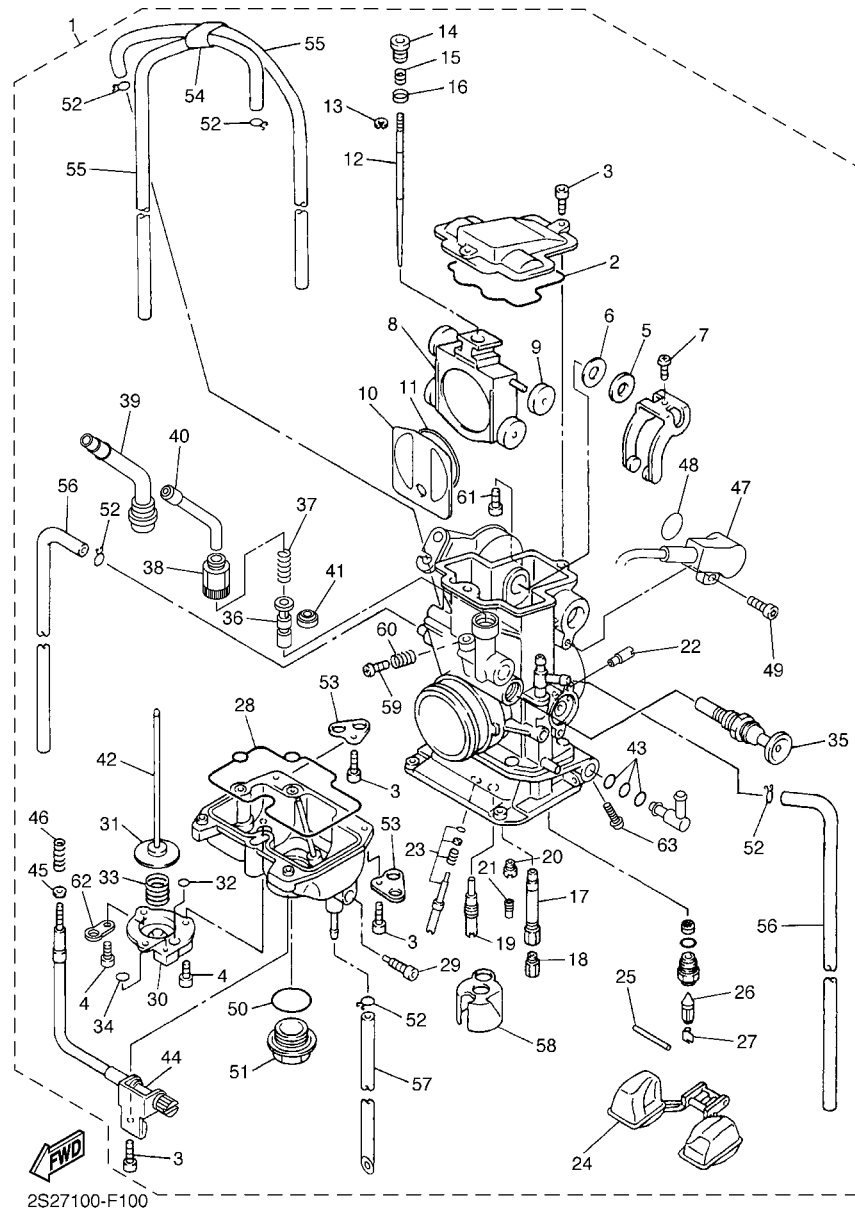
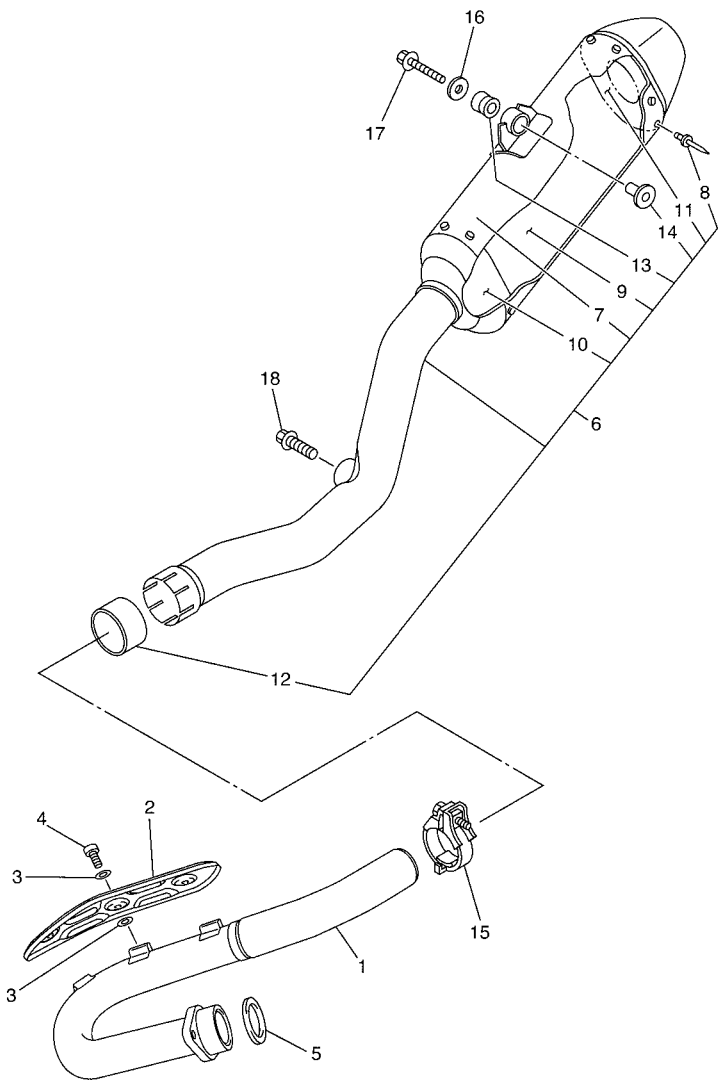

FIG. 10 CARBURETOR

REF. NO.	PART NO.	DESCRIPTION	5XCR	5XCS	5XCT	5XCU	REMARKS
40	5TA-14155-00	.GUIDE, CABLE	1	1	1	1	
41	5TA-14997-00	.SEAL	1	1	1	1	
42	5JG-14379-00	.ROD, STARTER	1	1	1	1	
43	3TJ-14564-40	.O-RING	3	3	3	3	
44	5XC-14922-00	.SCREW, THROTTLE	1	1	1	1	
45	90201-08410	.WASHER, PLATE	1	1	1	1	
46	5TA-14934-00	.SPRING, THROTTLE STOP	1	1	1	1	
47	5XC-85885-00	.THROTTLE SENSOR ASSY	1	1	1	1	
48	5NX-14562-00	.O-RING	1	1	1	1	
49	5NX-14216-00	.SCREW	1	1	1	1	
50	4MX-14561-00	.O-RING	1	1	1	1	
51	4MX-14115-00	.PLUG, SCREW	1	1	1	1	
52	3TJ-14137-40	.CLIP	5	5	5	5	
53	5BE-14146-00	.PLATE	2	2	2	2	
54	5TA-14261-00	.HOLDER	1	1	1	1	
55	5UL-14196-00	.PIPE	2	2	2	2	
56	5TA-14197-00	.PIPE	2	2	2	2	
57	5TJ-14987-00	.HOSE	1	1	1	1	
58	5JG-14346-00	.PLATE	1	1	1	1	
59	5JG-14565-00	.SCREW	1	1	1	1	
60	5JG-14531-00	.SPRING, ADJUST SCREW	1	1	1	1	
61	5NL-14591-00	.SCREW	1	1	1	1	
62	5PA-14146-00	.PLATE	1	1	1	1	
63	5XD-14325-00	.SCREW, PAN HEAD	1	1	1	1	

FIG. 11 EXHAUST



FWD
5XCR100-H110

REF. NO.	PART NO.	DESCRIPTION	5XCR	5XCS	5XCT	5XCU	REMARKS
1	5XC-14611-R0	PIPE, EXHAUST 1	1				
2	5XC-14628-R0	PROTECTOR, EXHAUST PIPE	1				
3	90201-05017	WASHER, PLATE	6				
4	98980-06008	SCREW, BIND	3				
5	5NL-14613-00	GASKET, EXHAUST PIPE	1				
6	5XC-14750-R0	SILENCER ASSY	1				
7	5XC-1466G-R0	.BODY, SILENCER	1				
8	90267-48084	.RIVET, BLIND	16				
9	5XC-1469A-R0	.FIBER	1				
10	2S2-1469E-00	.FIBER	1				
11	2S2-1469F-00	.FIBER	1				
12	5XD-14714-00	.GASKET, MUFFLER	1				
13	5BE-14747-00	.DAMPER, MUFFLER	1				
14	90387-08081	.COLLAR	1				
15	5BE-14788-00	BAND, SILENCER	1				
16	90201-08061	WASHER, PLATE	1				
17	90105-08137	BOLT, FLANGE	1				
18	90105-08307	BOLT, FLANGE	1				

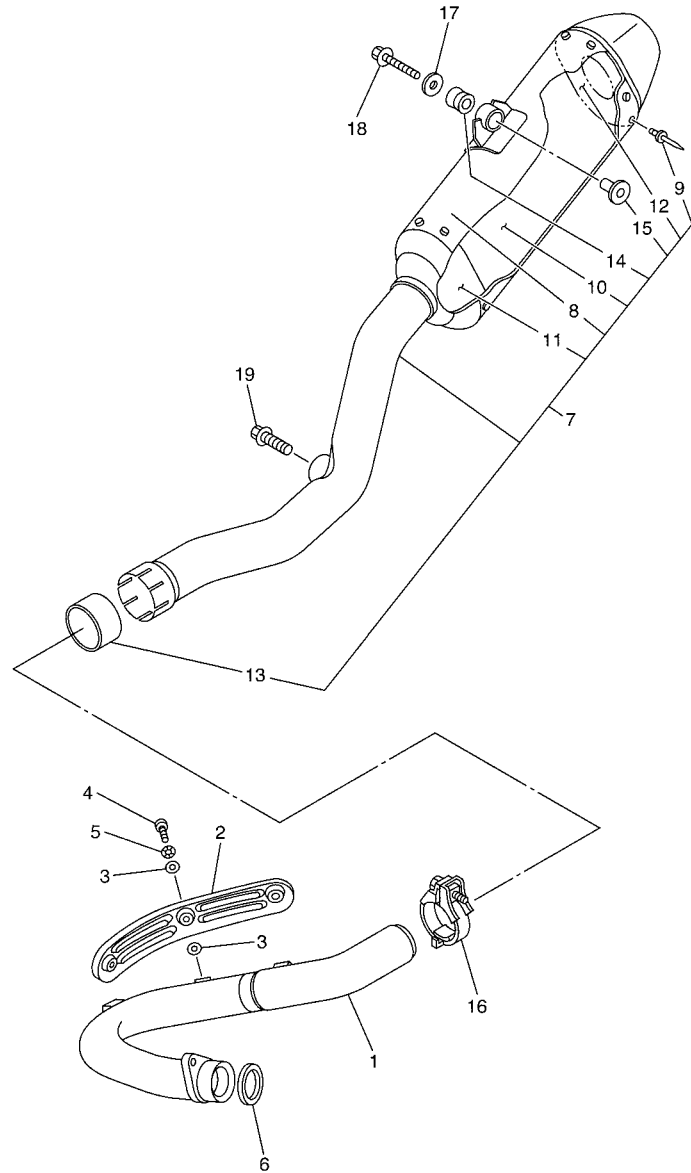

5XCL100-G110

FIG. 12 EXHAUST 2

REF. NO.	PART NO.	DESCRIPTION	5XCR	5XCS	5XCT	5XCU	REMARKS
1	5XC-14611-20	PIPE, EXHAUST 1		1	1	1	
2	5XC-14628-00	PROTECTOR, EXHAUST PIPE		1	1	1	
3	4BD-14766-00	WASHER, PROTECTOR		6	6	6	
4	98980-06008	SCREW, BIND		3	3	3	
5	90206-06090	WASHER, WAVE		3	3	3	
6	5NL-14613-00	GASKET, EXHAUST PIPE		1	1	1	
7	5XC-14750-S0	SILENCER ASSY		1	1	1	
8	5XC-1466G-S0	.BODY, SILENCER		1	1	1	
9	90267-48084	.RIVET, BLIND		16	16	16	
10	5XC-1469A-10	.FIBER		1	1	1	
11	2S2-1469E-00	.FIBER		1	1	1	
12	2S2-1469F-00	.FIBER		1	1	1	
13	5XD-14714-00	.GASKET, MUFFLER		1	1	1	
14	5BE-14747-00	.DAMPER, MUFFLER		1	1	1	
15	90387-08081	.COLLAR		1	1	1	
16	5BE-14788-00	BAND, SILENCER		1	1	1	
17	90201-08061	WASHER, PLATE		1	1	1	
18	90105-08137	BOLT, FLANGE		1	1	1	
19	90105-08307	BOLT, FLANGE		1	1	1	

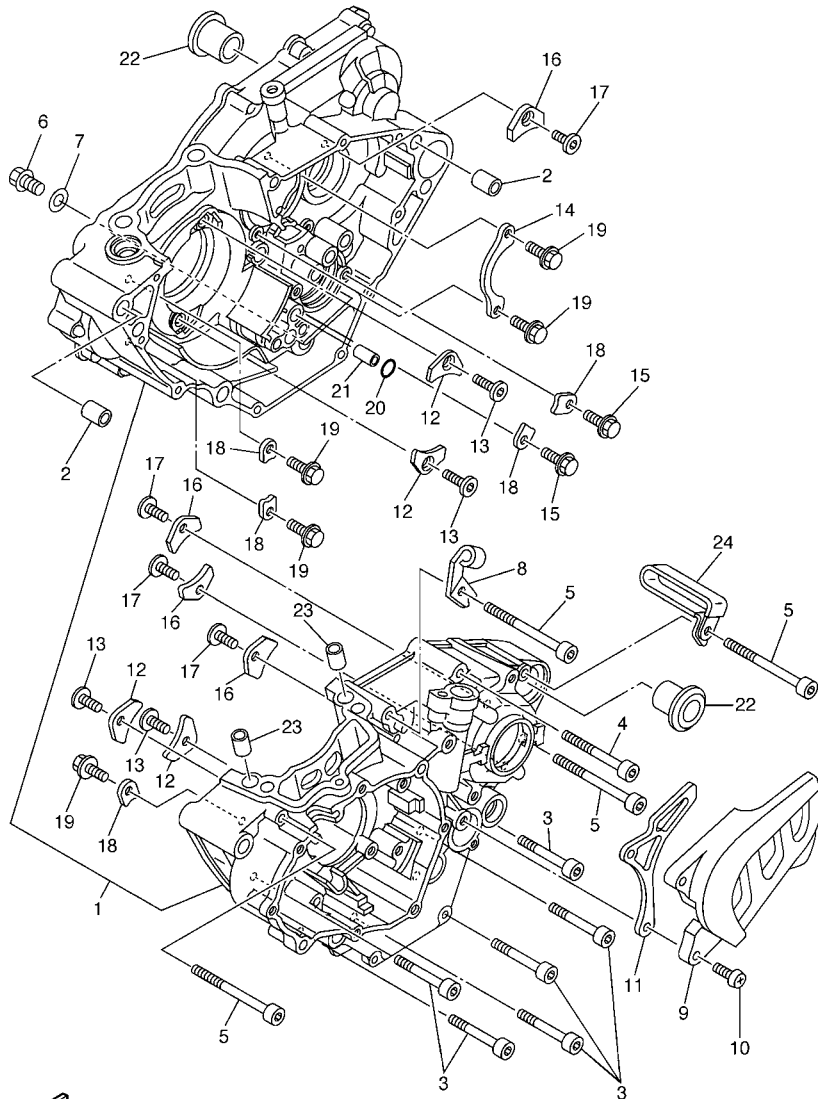

5XC9100-E120

FIG. 13 CRANKCASE

REF. NO.	PART NO.	DESCRIPTION	5XCR	5XCS	5XCT	5XCU	REMARKS
1	5XC-15150-21-YX	CRANKCASE ASSY	1	1	1	1	
2	93612-16254	PIN, DOWEL	2	2	2	2	
3	91312-06045	BOLT	6	6	6	6	
4	91312-06055	BOLT	1	1	1	1	
5	91312-06070	BOLT	4	4	4	4	
6	95022-10016	BOLT, FLANGE	1	1	1	1	
7	90430-10188	GASKET	1	1	1	1	
8	5NL-15441-01	HOLDER, CLUTCH CABLE	1	1	1	1	
9	5BE-15421-30	COVER, CRANKCASE 2	1	1	1	1	
10	98502-06025	SCREW, PAN HEAD	2	2	2	2	
11	5NL-17466-00	GUIDE, CHAIN	1	1	1	1	
12	5BE-15383-01	PLATE, BEARING COVER	4	4	4	4	
13	90151-06044	SCREW, COUNTERSUNK	4	4	4	4	
14	5NL-15388-00	PLATE, BEARING COVER	1	1	1	1	
15	90105-06081	BOLT, FLANGE	2	2	2	2	
16	4JT-15381-01	PLATE, BEARING COVER	4	4	4	4	
17	90149-06074	SCREW	4	4	4	4	
18	5DH-18562-00	PLATE, STOPPER 2	5	5	5	5	
19	90105-06081	BOLT, FLANGE	5	5	5	5	
20	93210-10197	O-RING	1	1	1	1	
21	99530-10114	PIN, DOWEL	1	1	1	1	
22	90387-18007	COLLAR	2	2	2	2	
23	99530-10116	PIN, DOWEL	2	2	2	2	
24	90465-10013	CLAMP	1	1	1	1	

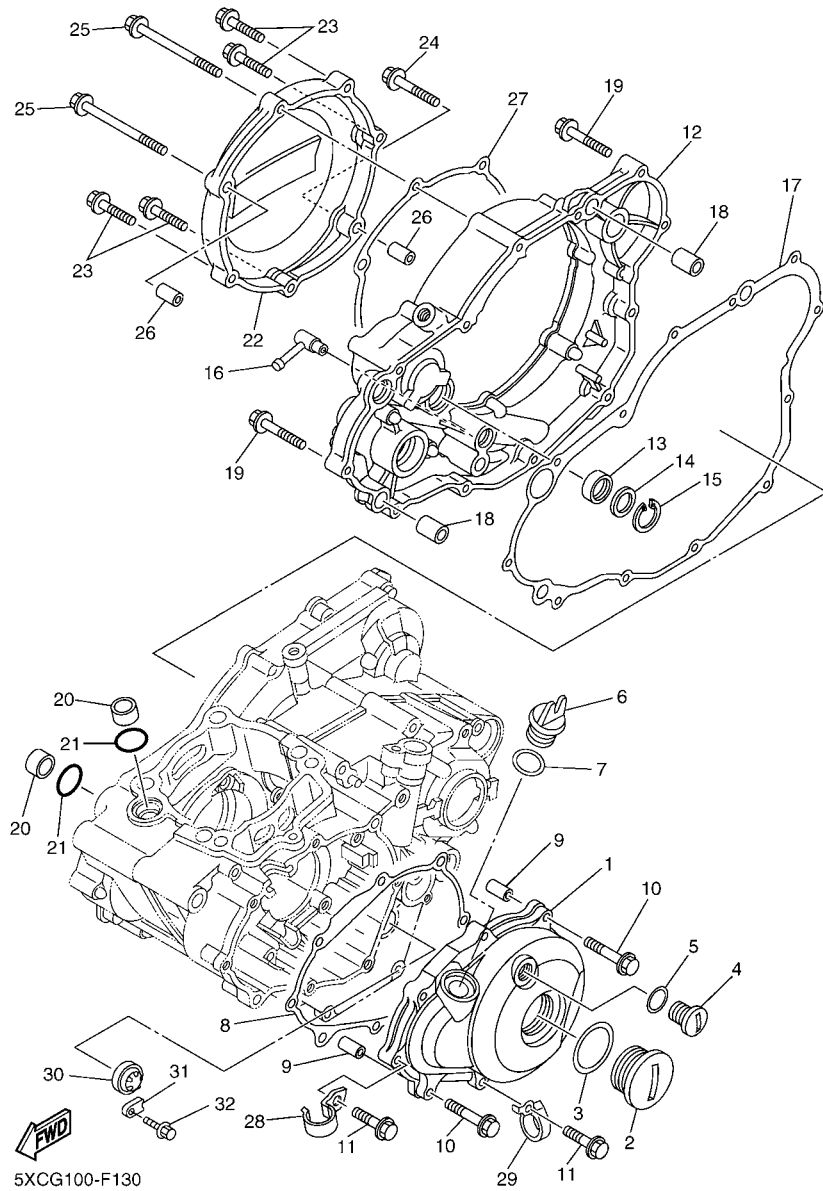

5XCG100-F130

FIG. 14 CRANKCASE COVER 1

REF. NO.	PART NO.	DESCRIPTION	5XCR	5XCS	5XCT	5XCU	REMARKS
1	5NL-15411-30	COVER, CRANKCASE 1	1	1	1	1	
2	90340-32006	PLUG, STRAIGHT SCREW	1	1	1	1	
3	93210-32172	O-RING	1	1	1	1	
4	90340-14015	PLUG, STRAIGHT SCREW	1	1	1	1	
5	93210-14369	O-RING	1	1	1	1	
6	3Y1-15363-00	PLUG, OIL	1	1	1	1	
7	93210-19123	O-RING	1	1	1	1	
8	5NL-15451-00	GASKET, CRANKCASE COVER 1	1	1	1	1	
9	99530-08016	PIN, DOWEL	2	2	2	2	
10	95022-06035	BOLT, FLANGE	2	2	2	2	
11	95022-06025	BOLT, FLANGE	6	6	6	6	
12	5XC-15431-01	COVER, CRANKCASE 3	1	1	1	1	
13	93101-14164	OIL SEAL	1	1	1	1	
14	90201-15701	WASHER, PLATE (T=1.0)	1	1	1	1	
15	99009-22500	CIRCLIP	1	1	1	1	
16	5XC-15373-00	PIPE, BREATHER	1	1	1	1	
17	5NL-15462-00	GASKET, CRANKCASE COVER 3	1	1	1	1	
18	91812-16001	PIN, DOWEL	2	2	2	2	
19	95022-06035	BOLT, FLANGE	8	8	8	8	
20	5NL-12564-00	PIPE, WATER	2	2	2	2	
21	93210-16716	O-RING	2	2	2	2	
22	5NL-15415-30	COVER, GENERATOR	1	1	1	1	
23	95022-06025	BOLT, FLANGE	4	4	4	4	
24	95022-06035	BOLT, FLANGE	1	1	1	1	
25	90105-06098	BOLT, FLANGE	2	2	2	2	
26	99530-08016	PIN, DOWEL	2	2	2	2	
27	5NL-15453-10	GASKET	1	1	1	1	

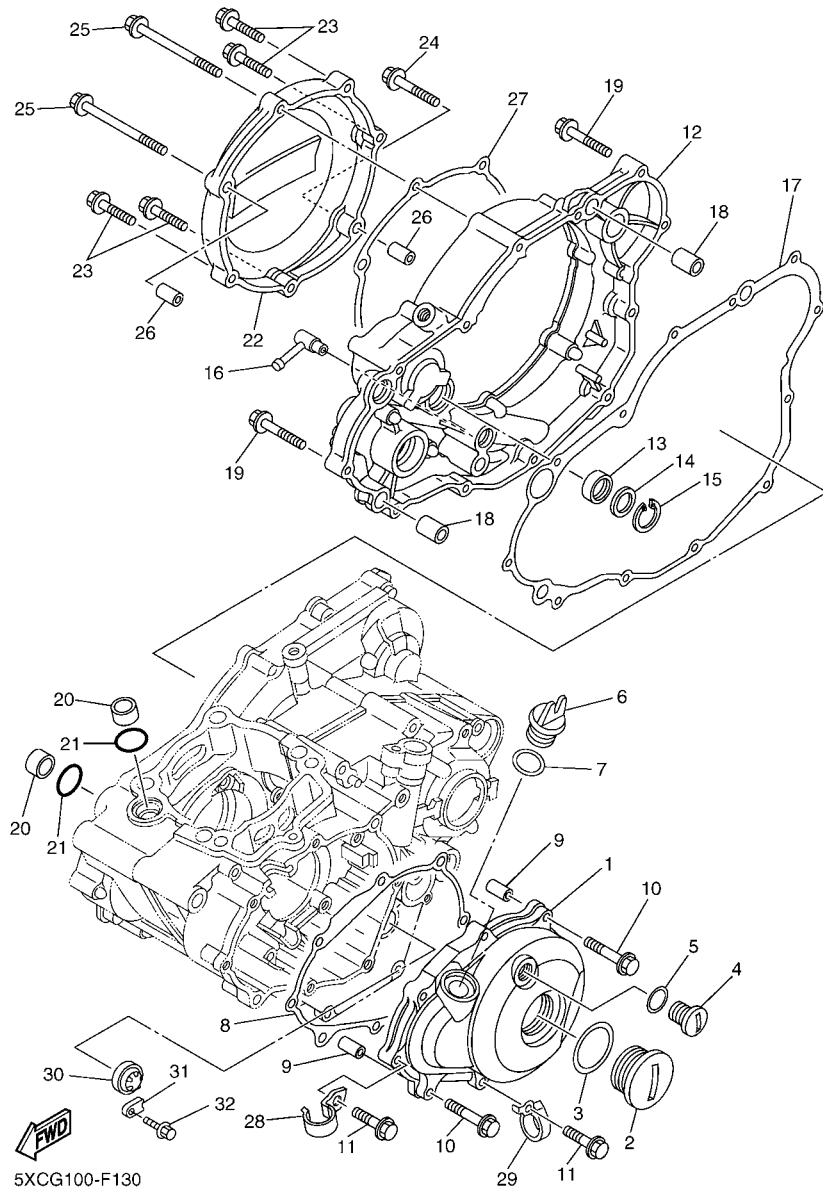
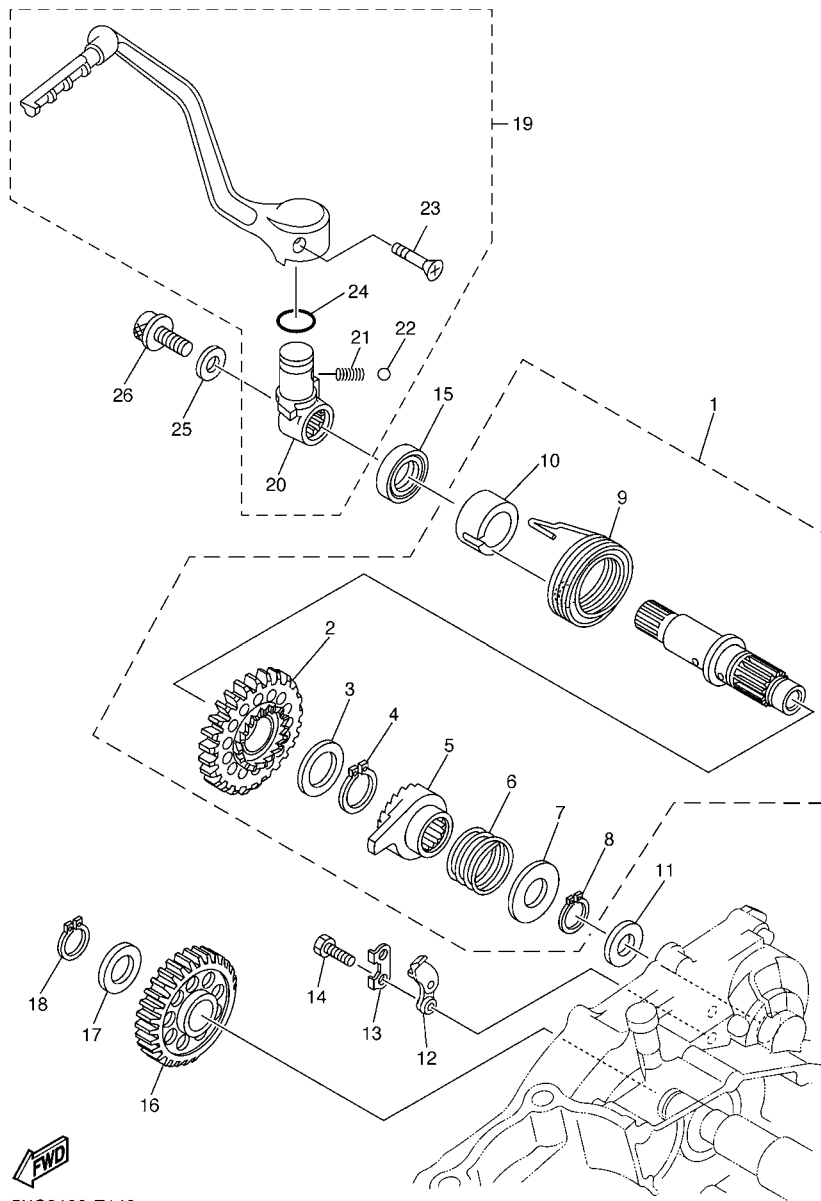

FIG. 14 CRANKCASE COVER 1

REF. NO.	PART NO.	DESCRIPTION	5XCR	5XCS	5XCT	5XCU	REMARKS
28	90465-08029	CLAMP	1	1	1	1	
29	2S2-15378-00	HOLDER	1	1	1	1	
30	3Y1-15361-00	GAUGE, LEVEL	1	1	1	1	
31	5XC-15118-00	HOLDER	1	1	1	1	
32	90105-06094	BOLT, FLANGE	1	1	1	1	
<hr/>							
<hr/>							
<hr/>							
<hr/>							
<hr/>							
<hr/>							
<hr/>							
<hr/>							
<hr/>							
<hr/>							
<hr/>							



5XC9100-E140

FIG. 15 STARTER

REF. NO.	PART NO.	DESCRIPTION	5XCR	5XCS	5XCT	5XCU	REMARKS
1	5NL-15601-20	KICK SHAFT ASSY	1	1	1	1	
2	5NL-15641-20	.GEAR, KICK	1	1	1	1	
3	90201-20685	.WASHER, PLATE (T=0.5)	1	1	1	1	
4	93410-20038	.CIRCLIP	1	1	1	1	
5	2S2-15671-00	.WHEEL, RATCHET	1	1	1	1	
6	90501-160A2	.SPRING, COMPRESSION	1	1	1	1	
7	90201-167P7	.WASHER, PLATE	1	1	1	1	
8	99009-16400	.CIRCLIP	1	1	1	1	
9	90508-30743	.SPRING, TORSION	1	1	1	1	
10	5NL-15664-00	.GUIDE, SPRING	1	1	1	1	
11	90201-162H4	WASHER, PLATE	1	1	1	1	
12	5SG-15668-00	STOPPER	1	1	1	1	
13	214-15686-00	WASHER, LOCK	1	1	1	1	
14	90101-06044	BOLT	2	2	2	2	
15	93102-18278	OIL SEAL	1	1	1	1	
16	5NL-15651-00	GEAR, KICK IDLE	1	1	1	1	
17	90201-177G4	WASHER, PLATE	1	1	1	1	
18	99009-17400	CIRCLIP	1	1	1	1	
19	5XC-15620-10	KICK CRANK ASSY	1	1	1	1	
20	5XC-15621-10	.BOSS, KICK CRANK	1	1	1	1	
21	90501-147A5	.SPRING, COMPRESSION	1	1	1	1	
22	93507-32009	.BALL	1	1	1	1	
23	90152-06010	.SCREW, COUNTERSUNK	1	1	1	1	
24	93210-17570	.O-RING	1	1	1	1	
25	90201-08048	WASHER, PLATE	1	1	1	1	
26	90110-08051	BOLT, HEXAGON SOCKET HEAD	1	1	1	1	

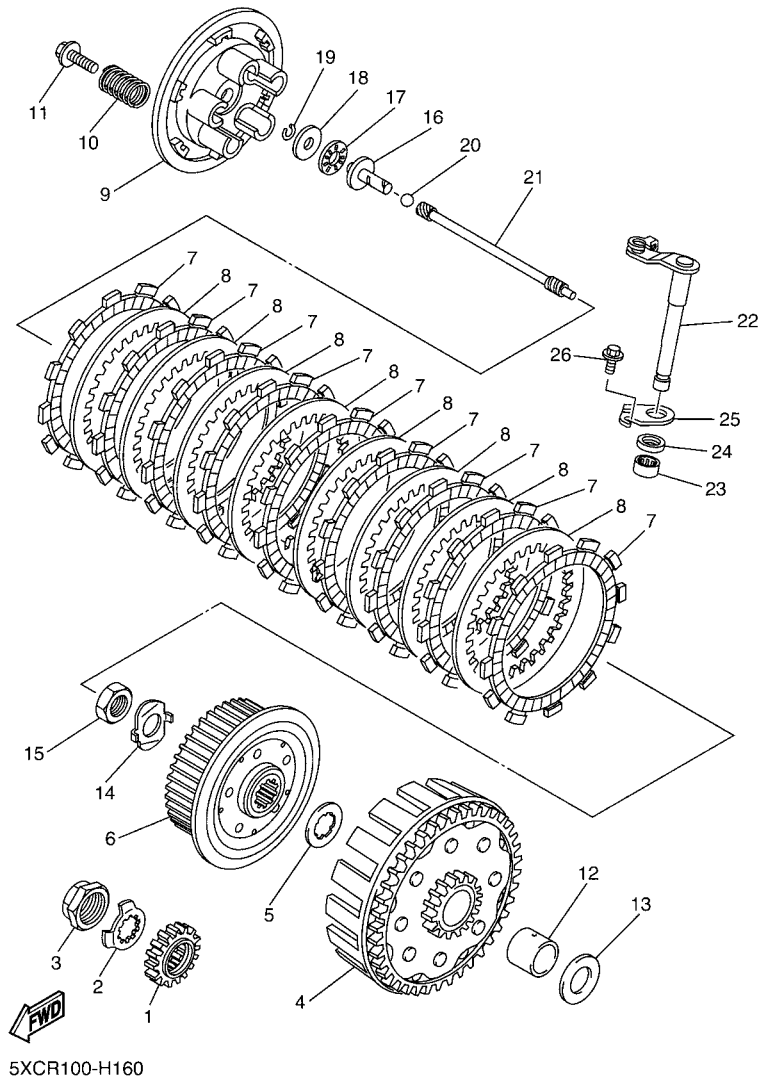

FIG. 16 CLUTCH

REF. NO.	PART NO.	DESCRIPTION	5XCR	5XCS	5XCT	5XCU	REMARKS
1	5NL-16111-01	GEAR, PRIMARY DRIVE	1	1	1	1	
2	90215-20003	WASHER, LOCK	1	1	1	1	
3	90179-18001	NUT	1	1	1	1	
4	5XC-16150-10	PRIMARY DRIVEN GEAR COMP.	1	1	1	1	
5	5XC-16154-00	PLATE, THRUST 1	1	1	1	1	
6	5NL-16371-30	BOSS, CLUTCH	1	1	1	1	
7	5XC-16321-00	PLATE, FRICTION	9	9	9	9	
8	5NL-16325-00	PLATE, CLUTCH 2	8	8	8	8	
9	5HD-16351-00	PLATE, PRESSURE 1	1	1	1	1	
10	90501-230A2	SPRING, COMPRESSION	5	5	5	5	
11	90159-06049	SCREW, WITH WASHER	5	5	5	5	
12	5XC-16181-00	SPACER 1	1	1	1	1	
13	90201-22013	WASHER, PLATE	1	1	1	1	
14	90215-16289	WASHER, LOCK	1	1	1	1	
15	90170-16326	NUT	1	1	1	1	
16	5XC-16356-00	ROD, PUSH 1	1	1	1	1	
17	93340-21008	BEARING	1	1	1	1	
18	90201-080H1	WASHER, PLATE	1	1	1	1	
19	93440-07182	CIRCLIP	1	1	1	1	
20	93511-32027	BALL	1	1	1	1	
21	5NL-16357-10	ROD, PUSH 2	1	1	1	1	
22	5XC-16381-00	PUSH LEVER COMP.	1	1	1	1	
23	93317-11287	BEARING	1	1	1	1	
24	93102-12224	OIL SEAL	1	1	1	1	
25	4JT-16384-00	PLATE, SEAT	1	1	1	1	
26	95022-06010	BOLT, FLANGE	1	1	1	1	

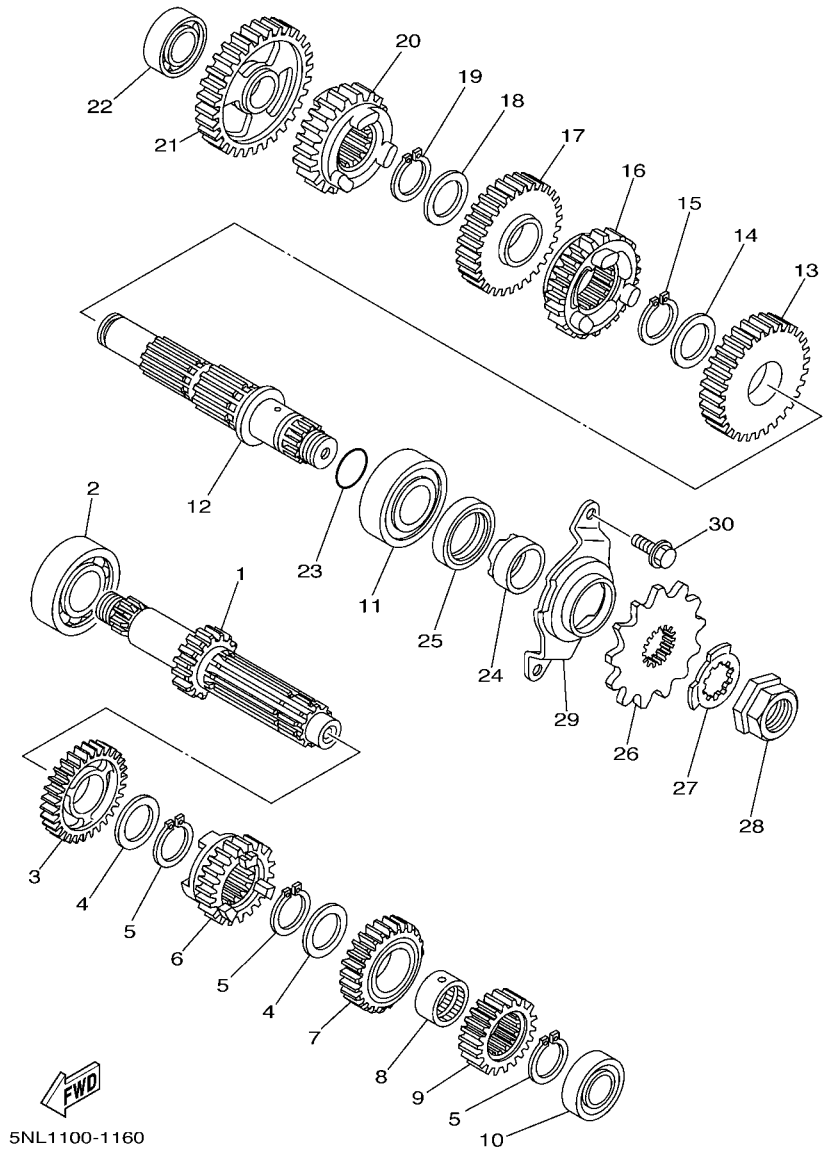
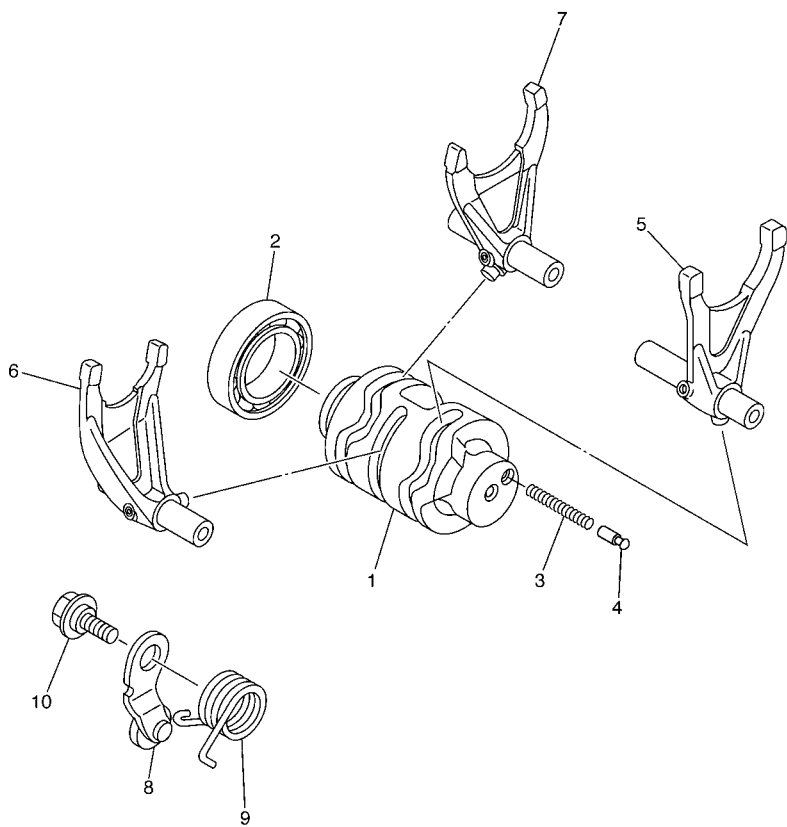

FIG. 17 TRANSMISSION

REF. NO.	PART NO.	DESCRIPTION	5XCR	5XCS	5XCT	5XCU	REMARKS
1	5XC-17411-00	AXLE,MAIN (14T)	1	1	1	1	
2	93306-20447	BEARING	1	1	1	1	
3	5NL-17151-00	GEAR, 5TH PINION (24T)	1	1	1	1	
4	90209-20008	WASHER	2	2	2	2	
5	93410-22039	CIRCLIP	3	3	3	3	
6	5NL-17131-10	GEAR, 3RD PINION (20T)	1	1	1	1	
7	5NL-17141-11	GEAR, 4TH PINION (22T)	1	1	1	1	
8	90387-20006	COLLAR	1	1	1	1	
9	5NL-17121-00	GEAR, 2ND PINION (16T)	1	1	1	1	
10	93306-00320	BEARING	1	1	1	1	
11	93306-27208	BEARING	1	1	1	1	
12	5NL-17402-00	DRIVE AXLE ASSY	1	1	1	1	
13	5NL-17221-00	GEAR, 2ND WHEEL (28T)	1	1	1	1	
14	90209-23012	WASHER	1	1	1	1	
15	93410-26067	CIRCLIP	1	1	1	1	
16	5NL-17241-11	GEAR, 4TH WHEEL (27T)	1	1	1	1	
17	5NL-17231-11	GEAR, 3RD WHEEL (29T)	1	1	1	1	
18	90209-20008	WASHER	1	1	1	1	
19	93410-22039	CIRCLIP	1	1	1	1	
20	5NL-17251-10	GEAR, 5TH WHEEL (25T)	1	1	1	1	
21	5NL-17211-10	GEAR, 1ST WHEEL (30T)	1	1	1	1	
22	93306-00317	BEARING	1	1	1	1	
23	93210-196A4	O-RING	1	1	1	1	
24	90387-22001	COLLAR	1	1	1	1	
25	93102-28010	OIL SEAL	1	1	1	1	
26	9383B-13218	SPROCKET, DRIVE (13T)	1	1	1	1	
27	90215-20003	WASHER, LOCK	1	1	1	1	

FIG. 18 SHIFT CAM & FORK



REF. NO.	PART NO.	DESCRIPTION	5XCR	5XCS	5XCT	5XCU	REMARKS
1	5NL-18541-00	CAM, SHIFT	1	1	1	1	
2	93306-90509	BEARING	1	1	1	1	
3	90501-06022	SPRING, COMPRESSION	1	1	1	1	
4	4UN-18542-00	POINT, NEUTRAL	1	1	1	1	
5	5NL-18501-00	FORK, SHIFT 1	1	1	1	1	
6	5NL-18502-00	FORK, SHIFT 2	1	1	1	1	
7	5NL-18503-00	FORK, SHIFT 3	1	1	1	1	
8	3XK-18140-00	STOPPER LEVER ASSY	1	1	1	1	
9	90508-26561	SPRING, TORSION	1	1	1	1	
10	90109-06193	BOLT	1	1	1	1	

FWD
5XC9100-E170

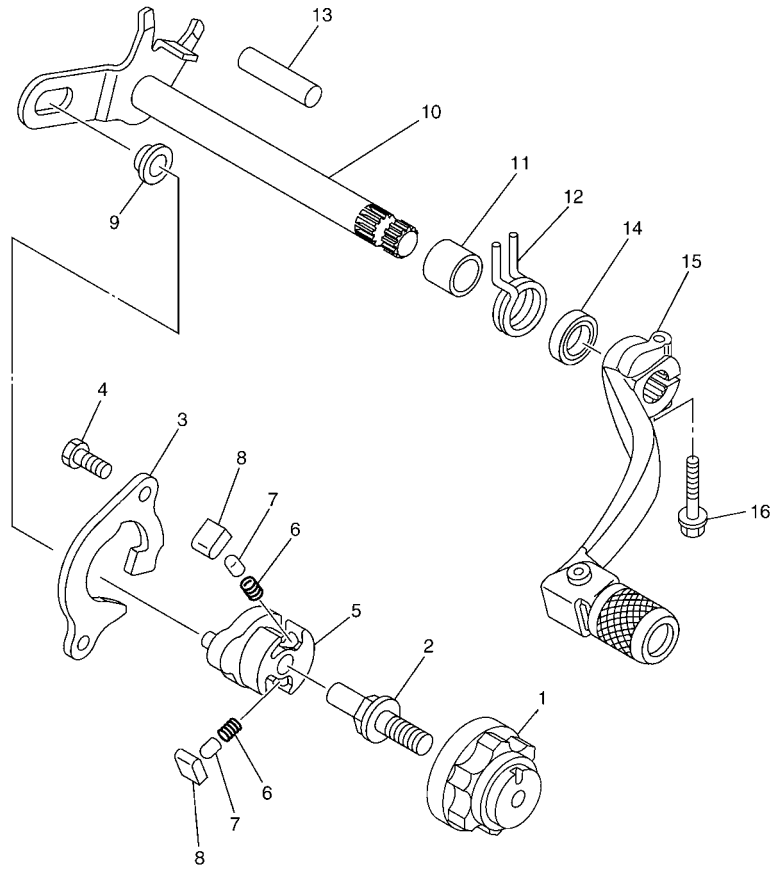

5XCG100-F180

FIG. 19 SHIFT SHAFT

REF. NO.	PART NO.	DESCRIPTION	5XCR	5XCS	5XCT	5XCU	REMARKS
1	2S2-18185-00	SEGMENT	1	1	1	1	
2	3XJ-18173-10	PIN, SHIFT	1	1	1	1	
3	5BE-18172-00	GUIDE, SHIFT	1	1	1	1	
4	90101-06041	BOLT	2	2	2	2	
5	5LP-18122-01	LEVER, SHIFT 2	1	1	1	1	
6	90501-052G5	SPRING, COMPRESSION	2	2	2	2	
7	3XJ-18184-00	PIN, PAWL	2	2	2	2	
8	3XJ-18182-00	PAWL, SHIFTER	2	2	2	2	
9	3XJ-18178-00	ROLLER, SHIFT LEVER	1	1	1	1	
10	5UL-18101-10	SHIFT SHAFT ASSY	1	1	1	1	
11	90387-124F4	COLLAR	1	1	1	1	
12	90508-291A8	SPRING, TORSION	1	1	1	1	
13	93608-33002	PIN, DOWEL	1	1	1	1	
14	93102-12224	OIL SEAL	1	1	1	1	
15	5XC-18110-10	SHIFT PEDAL ASSY	1	1	1	1	
16	95022-06020	BOLT, FLANGE	1	1	1	1	

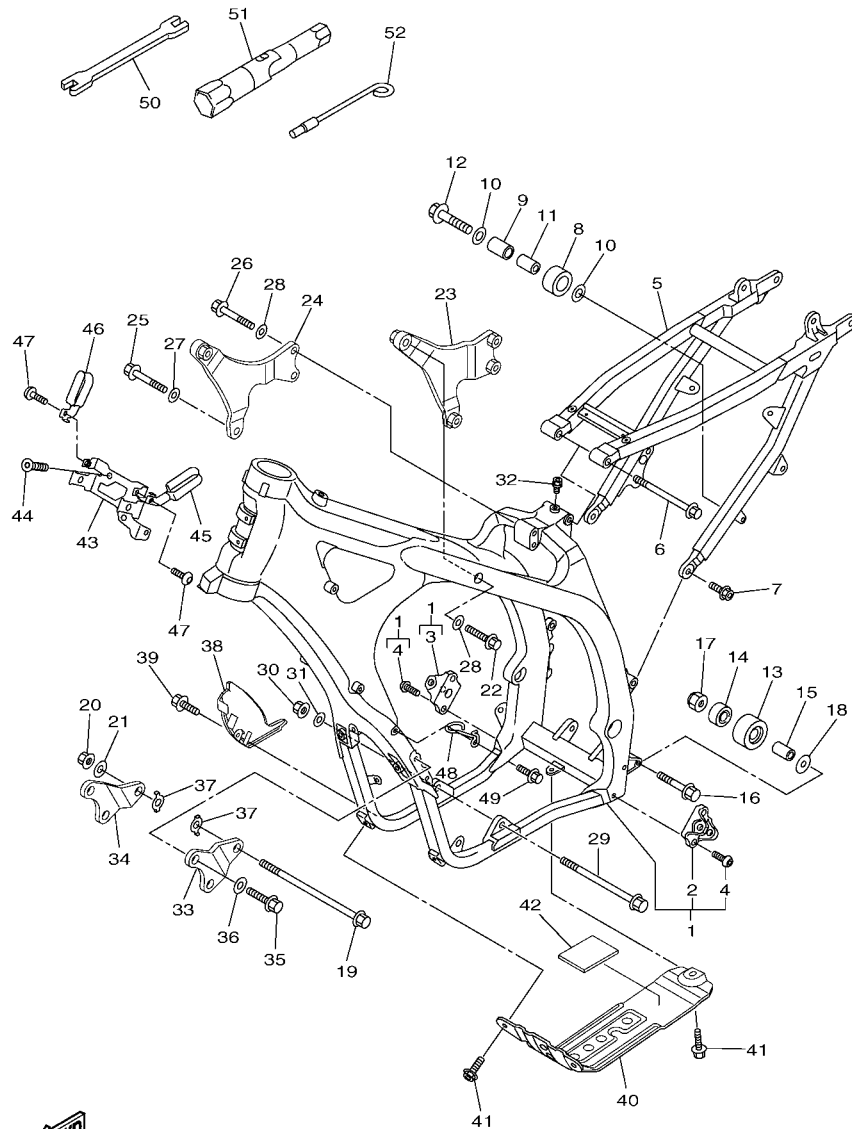

5XCG100-F190

FIG. 20 FRAME

REF. NO.	PART NO.	DESCRIPTION	5XCR	5XCS	5XCT	5XCU	REMARKS
1	5XC-21101-R1	FRONT FRAME COMP.	1	1	1	1	
2	1C3-21447-10	.BRACKET, FOOTREST	1	1	1	1	
3	1C3-21448-10	.BRACKET, FOOTREST	1	1	1	1	
4	90149-10031	.SCREW	4	4	4	4	
5	5XC-21190-L0	REAR FRAME COMP.	1	1	1	1	
6	90105-08156	BOLT, FLANGE	1	1	1	1	
7	90105-08307	BOLT, FLANGE	2	2	2	2	
8	30X-22178-00	TENSIONER	1	1	1	1	
9	4V4-22184-00	BUSH	1	1	1	1	
10	90201-08045	WASHER, PLATE	2	2	2	2	
11	90387-08041	COLLAR	1	1	1	1	
12	95022-08040	BOLT, FLANGE	1	1	1	1	
13	3JD-22178-20	TENSIONER	1	1	1	1	
14	93300-60839	BEARING	1	1	1	1	
15	90387-086N4	COLLAR	1	1	1	1	
16	90105-08146	BOLT, FLANGE	1	1	1	1	
17	90185-08009	NUT, SELF-LOCKING	1	1	1	1	
18	90201-08043	WASHER, PLATE	1	1	1	1	
19	90105-10174	BOLT, FLANGE	1	1	1	1	
20	90179-10658	NUT	1	1	1	1	
21	90201-10045	WASHER, PLATE	1	1	1	1	
22	90105-08150	BOLT, FLANGE	2	2	2	2	
23	5XC-21425-G0	BRACKET, REAR UPPER 1	1	1	1	1	
24	5XC-21426-G0	BRACKET, REAR UPPER 2	1	1	1	1	
25	90105-10191	BOLT, FLANGE	1	1	1	1	
26	90105-08147	BOLT, FLANGE	2	2	2	2	
27	90201-10045	WASHER, PLATE	1	1	1	1	

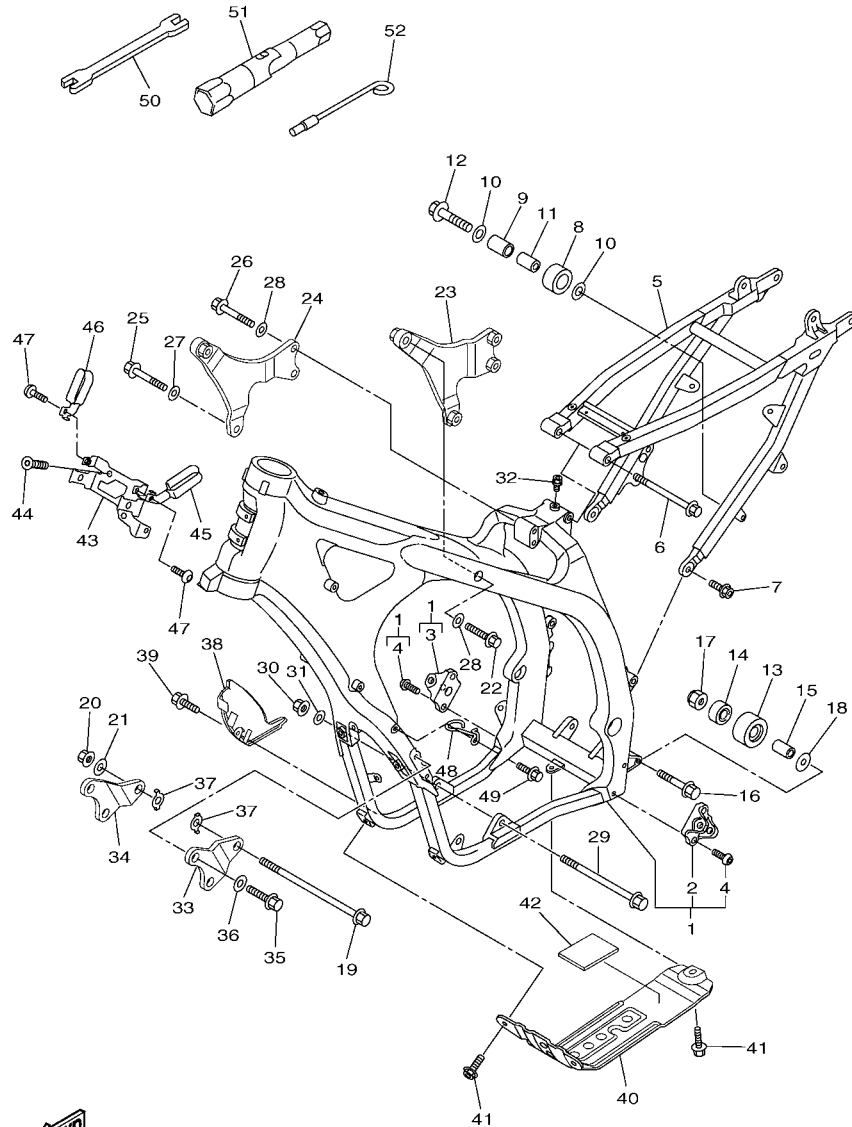

5XCG100-F190

FIG. 20 FRAME

REF. NO.	PART NO.	DESCRIPTION	5XCR	5XCS	5XCT	5XCU	REMARKS
28	92902-08200	WASHER	4	4	4	4	
29	90105-10176	BOLT, FLANGE	1	1	1	1	
30	90179-10658	NUT	1	1	1	1	
31	90201-10045	WASHER, PLATE	1	1	1	1	
32	1C3-21244-10	NUT	1	1	1	1	
33	5XC-21417-G0	BRACKET, FRONT LOWER 1	1	1	1	1	
34	5XC-21418-G0	BRACKET, FRONT LOWER 2	1	1	1	1	
35	90105-08143	BOLT, FLANGE	4	4	4	4	
36	92902-08200	WASHER	4	4	4	4	
37	5XC-21456-90	PLATE, PATCH	2	2	2	2	
38	5XC-21471-90	PROTECTOR, ENGINE	1	1	1	1	
39	90119-06146	BOLT, WITH WASHER	1	1	1	1	
40	5XC-2147E-G0	GUARD, ENGINE 2	1	1	1	1	
41	90119-06146	BOLT, WITH WASHER	3	3	3	3	
42	5XC-21486-90	DAMPER 2	1	1	1	1	
43	5XC-21274-90	BRACKET, C.D.I. UNIT	1	1	1	1	
44	90151-06032	SCREW, COUNTERSUNK	2	2	2	2	
45	5XC-21163-90	HOLDER, CLUTCH CABLE	1	1	1	1	
46	5XC-21164-90	HOLDER, CABLE	1	1	1	1	
47	92012-05008	BOLT, BUTTON HEAD	2	2	2	2	
48	5XC-21288-90	GUIDE, CABLE	1	1	1	1	
49	90105-05014	BOLT, FLANGE	1	1	1	1	
50	5ET-28166-10	WRENCH, HEXAGON	1	1	1	1	
51	5TA-2814F-00	BOX, SPARK PLUG	1	1	1	1	
52	5XC-28116-00	TOOL, SPECIAL	1	1	1	1	

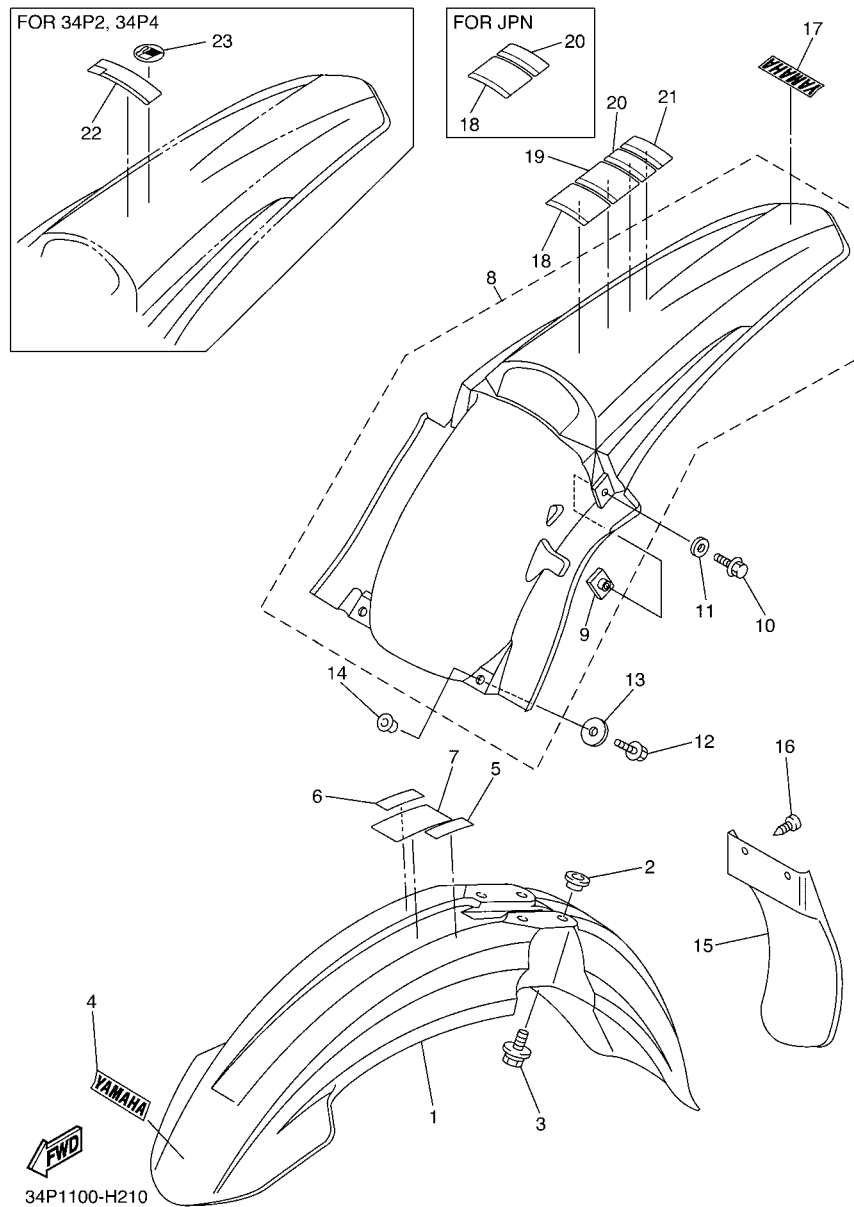

FIG. 21 FENDER

REF. NO.	PART NO.	DESCRIPTION	5XCR	5XCS	5XCT	5XCU	REMARKS
1	1C3-21511-51	FENDER, FRONT	1	1	1	1	UR FOR DPBSE
	2S2-21511-70	FENDER, FRONT	1	1	1	1	UR FOR PWS1
2	90387-06090	COLLAR	4	4	4	4	
3	90119-06147	BOLT, WITH WASHER	4	4	4	4	
4	4ES-2153E-01	EMBLEM, YAMAHA	1	1	1	1	UR FOR DPBSE
	4ES-2153E-20	EMBLEM, YAMAHA	1	1	1	1	UR FOR PWS1
5	3FB-2415E-02	LABEL, CAUTION	1				
	3FB-2415E-C1	LABEL, CAUTION			1		JAPANESE
6	3FB-2415E-12	LABEL, CAUTION	1				
7	4SR-2416E-00	LABEL, CAUTION CANADA	1				
8	5XC-21610-90	REAR FENDER COMP.	1	1	1	1	UR FOR DPBSE
	2S2-21610-70	REAR FENDER COMP.	1	1	1	1	UR FOR PWS1
9	5XE-21635-10	.NUT, REAR FENDER	2	2	2	2	
10	90105-06100	BOLT, FLANGE	2	2	2	2	
11	90201-06104	WASHER, PLATE	2	2	2	2	
	90105-06106	BOLT, FLANGE	2	2	2	2	
13	90201-06085	WASHER, PLATE	2	2	2	2	
14	90387-06009	COLLAR	2	2	2	2	
15	5TA-21642-00	GUARD, FLAP	1	1	1	1	
16	97702-60016	SCREW, TAPPING	2	2	2	2	
	3WF-2153E-10	EMBLEM, YAMAHA	1	1	1	1	UR FOR DPBSE
	3WF-2153E-40	EMBLEM, YAMAHA	1	1	1	1	UR FOR PWS1
18	5PA-2118K-00	LABEL, CAUTION	1				
	5PA-2118K-20	LABEL, CAUTION			1		
19	5PA-2118K-10	LABEL, CAUTION	1				
	3XJ-2151H-A1	LABEL 5	1				
	4LB-2151H-02	LABEL 5			1		JAPANESE

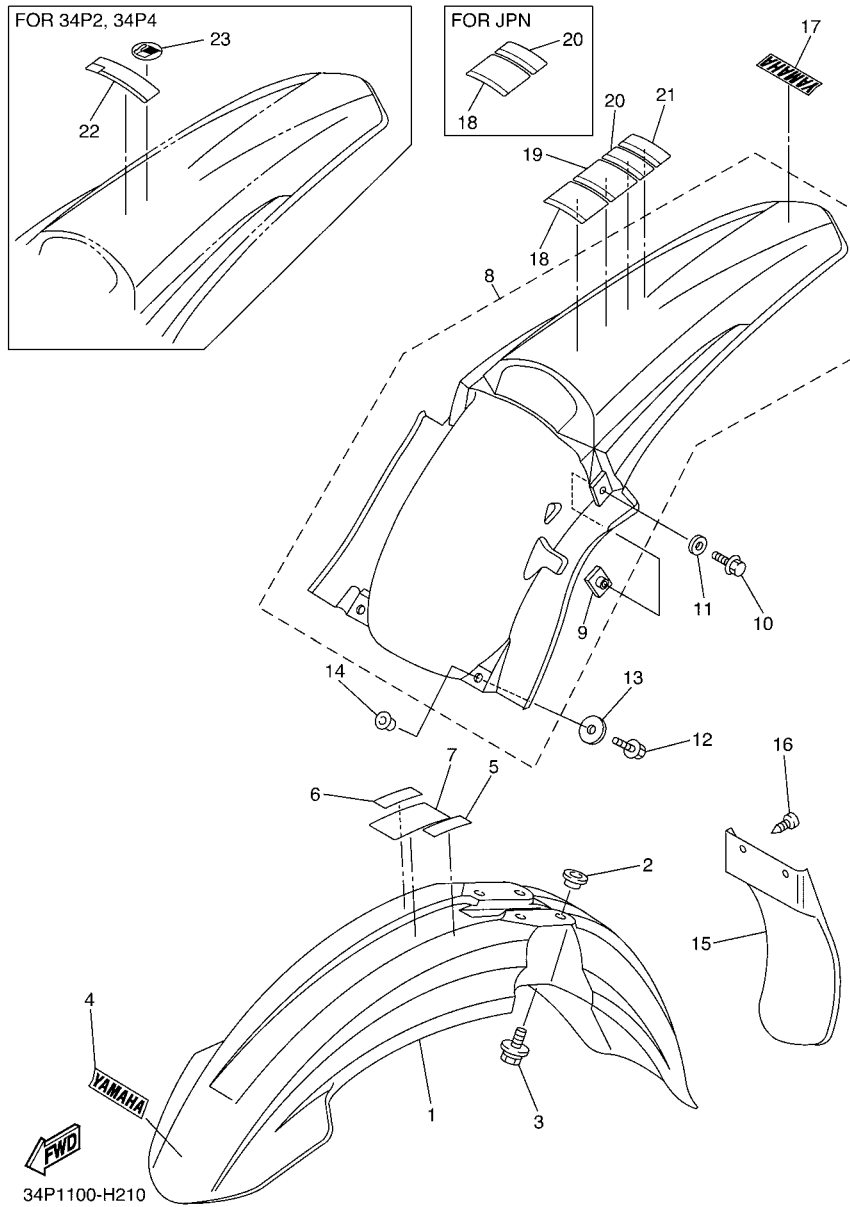

FIG. 21 FENDER

REF. NO.	PART NO.	DESCRIPTION	5XCR	5XCS	5XCT	5XCU	REMARKS
21	3XJ-2151H-B1	LABEL 5	1				
22	5RU-21568-01	LABEL, WARNING		1		1	
23	3ME-2415E-01	LABEL, CAUTION		1			

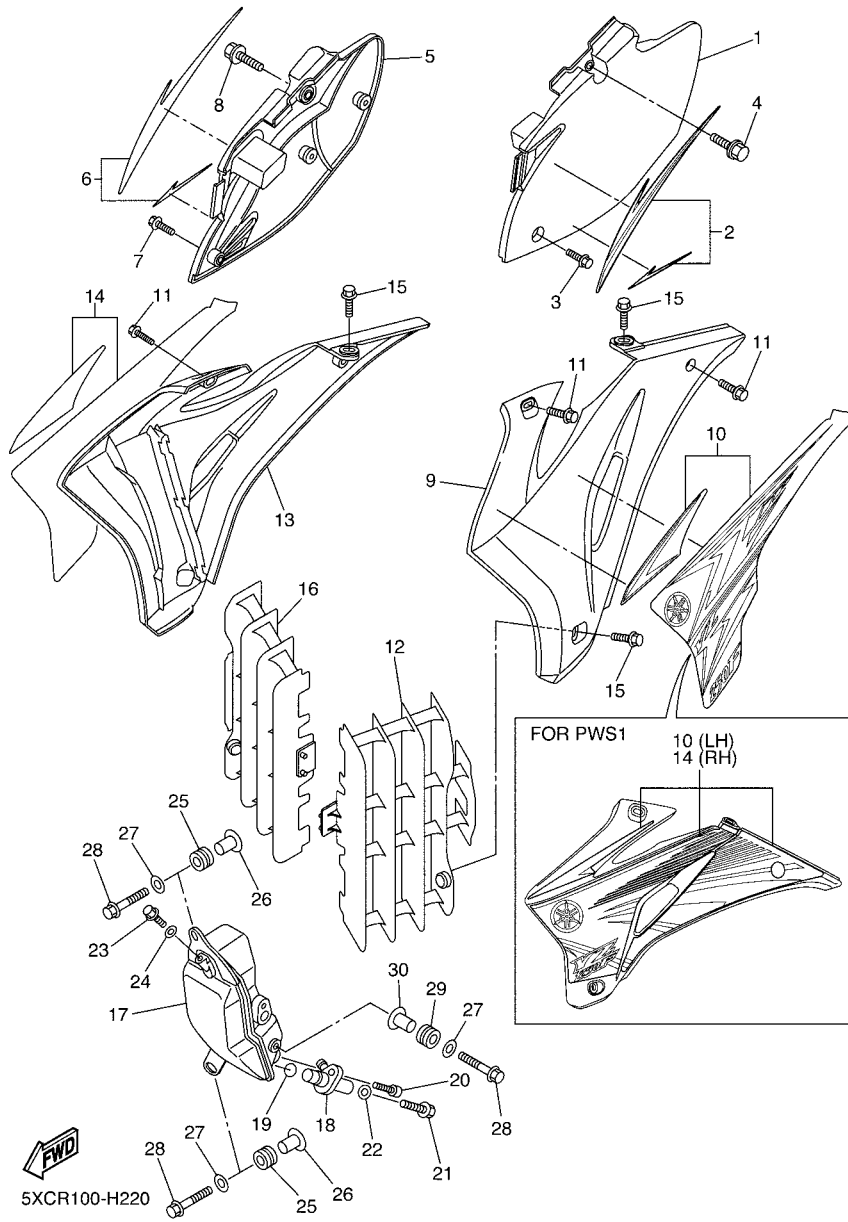

FIG. 22 SIDE COVER & OIL TANK

REF. NO.	PART NO.	DESCRIPTION	5XCR	5XCS	5XCT	5XCU	REMARKS
1	5XC-21710-90	SIDE COVER ASSY 1	1	1	1	1	
2	34P-2167A-00	GRAPHIC SET	1	1	1	1	UR FOR DPBSE
	34P-2167A-10	GRAPHIC SET	1	1	1	1	UR FOR PWS1
3	90105-06103	BOLT, FLANGE	1	1	1	1	
4	90119-08095	BOLT, WITH WASHER	1	1	1	1	
5	5XC-21720-90	SIDE COVER ASSY 2	1	1	1	1	
6	34P-2167B-00	GRAPHIC SET 2	1	1	1	1	UR FOR DPBSE
	34P-2167B-10	GRAPHIC SET 2	1	1	1	1	UR FOR PWS1
7	90105-06103	BOLT, FLANGE	1	1	1	1	
8	90119-08095	BOLT, WITH WASHER	1	1	1	1	
9	5XC-21730-90	SIDE COVER ASSY 3	1	1	1	1	UR FOR DPBSE
	2S2-21730-70	SIDE COVER ASSY 3	1	1	1	1	UR FOR PWS1
10	34P-2173L-10	GRAPHIC SET 1	1	1	1	1	UR FOR DPBSE
	5XC-2173L-40	GRAPHIC SET 1	1	1	1	1	UR FOR PWS1
11	90105-06064	BOLT, FLANGE	4	4	4	4	
12	2S2-2172A-70	PANEL 1	1	1	1	1	
13	5XC-21740-90	SIDE COVER ASSY 4	1	1	1	1	UR FOR DPBSE
	2S2-21740-70	SIDE COVER ASSY 4	1	1	1	1	UR FOR PWS1
14	34P-2174L-10	GRAPHIC SET 2	1	1	1	1	UR FOR DPBSE
	5XC-2174L-40	GRAPHIC SET 2	1	1	1	1	UR FOR PWS1
15	90105-06064	BOLT, FLANGE	4	4	4	4	
16	2S2-2172A-80	PANEL 1	1	1	1	1	
17	5XC-21751-G0	TANK, OIL	1	1	1	1	
18	5XC-13416-90	PIPE, OIL 1	1	1	1	1	
19	93210-14369	O-RING	1	1	1	1	
20	91312-06016	BOLT	1	1	1	1	
21	90105-08151	BOLT, FLANGE	1	1	1	1	

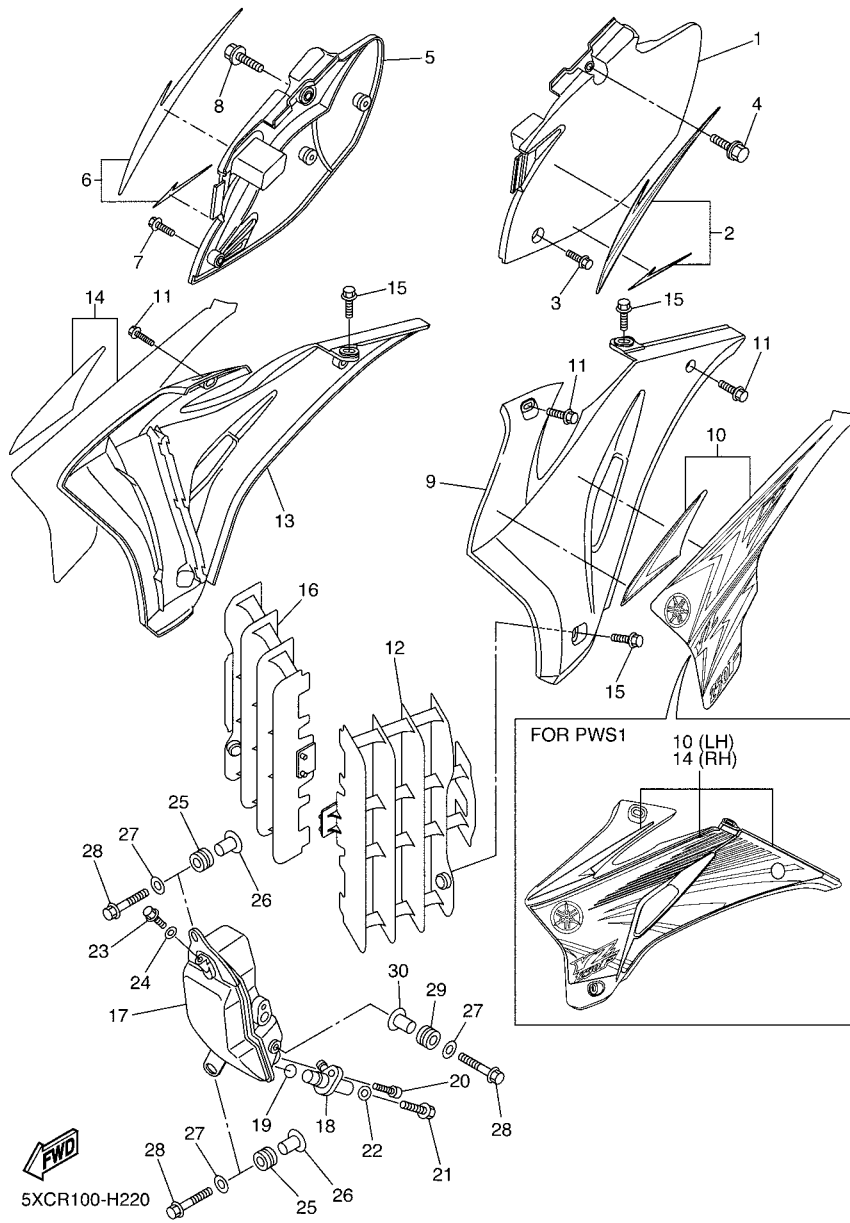

FIG. 22 SIDE COVER & OIL TANK

REF. NO.	PART NO.	DESCRIPTION	5XCR	5XCS	5XCT	5XCU	REMARKS
22	90201-082A6	WASHER, PLATE	1	1	1	1	
23	90105-06128	BOLT, FLANGE	1	1	1	1	
24	90201-06630	WASHER, PLATE	1	1	1	1	
25	90480-10289	GROMMET	2	2	2	2	
26	90387-06150	COLLAR	2	2	2	2	
27	90201-06571	WASHER, PLATE	3	3	3	3	
28	90105-06112	BOLT, FLANGE	3	3	3	3	
29	90480-14433	GROMMET	1	1	1	1	
30	90387-06161	COLLAR	1	1	1	1	

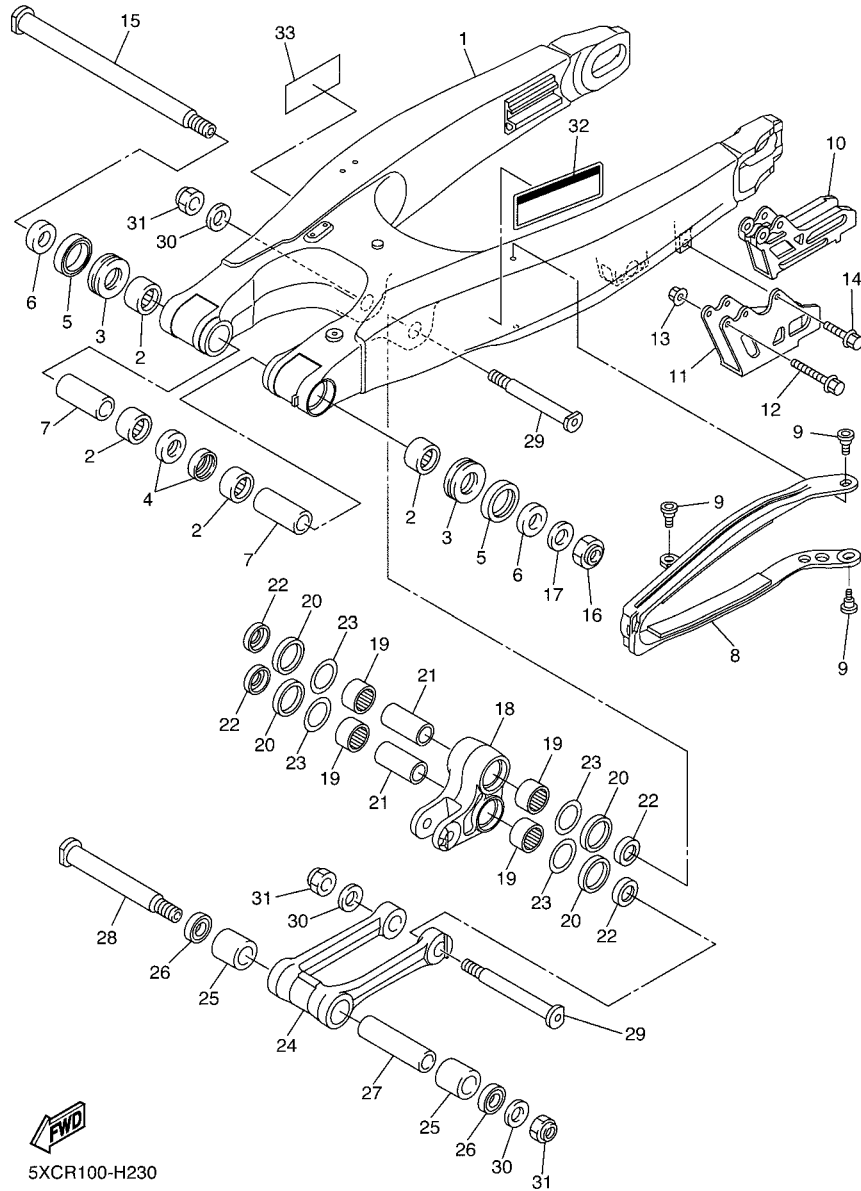
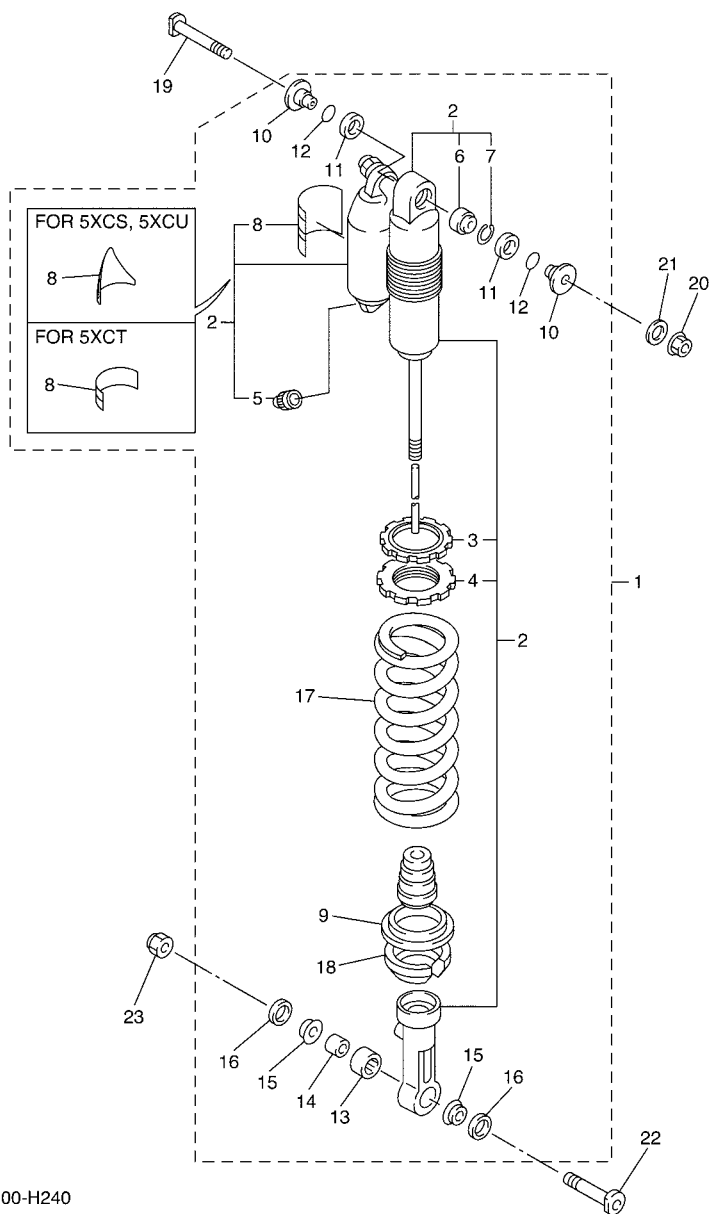

FIG. 23 REAR ARM

REF. NO.	PART NO.	DESCRIPTION	5XCR	5XCS	5XCT	5XCU	REMARKS
1	17D-22110-00	REAR ARM COMP.	1	1	1	1	
2	93317-22262	BEARING	4	4	4	4	
3	93342-22217	BEARING	2	2	2	2	
4	93106-22002	OIL SEAL	2	2	2	2	
5	93109-28043	OIL SEAL	2	2	2	2	
6	90387-18012	COLLAR	2	2	2	2	
7	90387-18004	COLLAR	2	2	2	2	
8	34P-22151-00	SEAL, GUARD	1	1	1	1	
9	1C3-22969-90	SCREW, 1	3	3	3	3	
10	2S2-22199-70	SUPPORT, CHAIN	1	1	1	1	
11	2S2-22128-70	COVER, THRUST 1	1	1	1	1	
12	90105-06104	BOLT, FLANGE	2	2	2	2	
13	90179-06028	NUT	2	2	2	2	
14	90105-06105	BOLT, FLANGE	1	1	1	1	
15	1C3-22141-10	SHAFT, PIVOT	1	1	1	1	
16	90185-16002	NUT, SELF-LOCKING	1	1	1	1	
17	90201-16018	WASHER, PLATE	1	1	1	1	
18	17D-2217A-00	ARM, RELAY	1	1	1	1	
19	93315-32166	BEARING	4	4	4	4	
20	93109-25001	OIL SEAL	4	4	4	4	
21	90387-16026	COLLAR	2	2	2	2	
22	90209-16011	WASHER	4	4	4	4	
23	90201-21014	WASHER, PLATE	4	4	4	4	
24	17D-2217F-00	ROD, CONNECTING 1	1	1	1	1	
25	93315-32166	BEARING	2	2	2	2	
26	93109-21001	OIL SEAL	2	2	2	2	
27	90387-14016	COLLAR	1	1	1	1	

FIG. 24 REAR SUSPENSION



5XCR100-H240

REF. NO.	PART NO.	DESCRIPTION	5XCR	5XCS	5XCT	5XCU	REMARKS
1	5XC-22200-60	SHOCK ABSORBER ASSY, REAR	1				UR FOR DPBSE
	5XC-22200-Y0	SHOCK ABSORBER ASSY, REAR	1				UR FOR PWS1
	5XC-22200-30	SHOCK ABSORBER ASSY, REAR		1	1		UR FOR DPBSE
	5XC-22200-80	SHOCK ABSORBER ASSY, REAR		1	1		UR FOR PWS1
	5XC-22200-40	SHOCK ABSORBER ASSY, REAR			1		UR FOR DPBSE
5XC-22200-90	SHOCK ABSORBER ASSY, REAR			1		UR FOR PWS1	
2	5XC-22201-60	.DAMPER SUB ASSY	1				UR FOR DPBSE
	5XC-22201-Y0	.DAMPER SUB ASSY	1				UR FOR PWS1
	5XC-22201-30	.DAMPER SUB ASSY		1	1		UR FOR DPBSE
	5XC-22201-80	.DAMPER SUB ASSY		1	1		UR FOR PWS1
	5XC-22201-40	.DAMPER SUB ASSY			1		UR FOR DPBSE
5XC-22201-90	.DAMPER SUB ASSY			1		UR FOR PWS1	
3	3SP-22234-00	..GUIDE, SPRING 3	1	1	1	1	
4	1C3-22213-L0	..SEAT, SPRING UPPER	1	1	1	1	
5	509-23184-L0	..CAP, AIR VALVE	1	1	1	1	
6	4JX-22226-00	..BUSH, SHOCK ABSORBER LOWER	1	1	1	1	
7	5DH-23183-00	..CIRCLIP	1	1	1	1	
8	4AA-22259-60	..LABEL, WARNING	1				
	4AA-22259-40	..LABEL, WARNING		1		1	
	4AA-22259-50	..LABEL, WARNING			1		
9	5MV-22224-00	..GUIDE, SPRING 2	1	1	1	1	
10	1C3-22253-50	.COLLAR, DISTANCE	2	2	2	2	
11	3JE-22475-00	.SEAL, DUST	2	2	2	2	
12	4EW-22474-00	.SEAL, RING	2	2	2	2	
13	5UN-22176-00	.BEARING	1	1	1	1	
14	5MV-22184-00	.BUSH	1	1	1	1	
15	1C3-22253-L0	.COLLAR, DISTANCE	2	2	2	2	



34P1100-H250

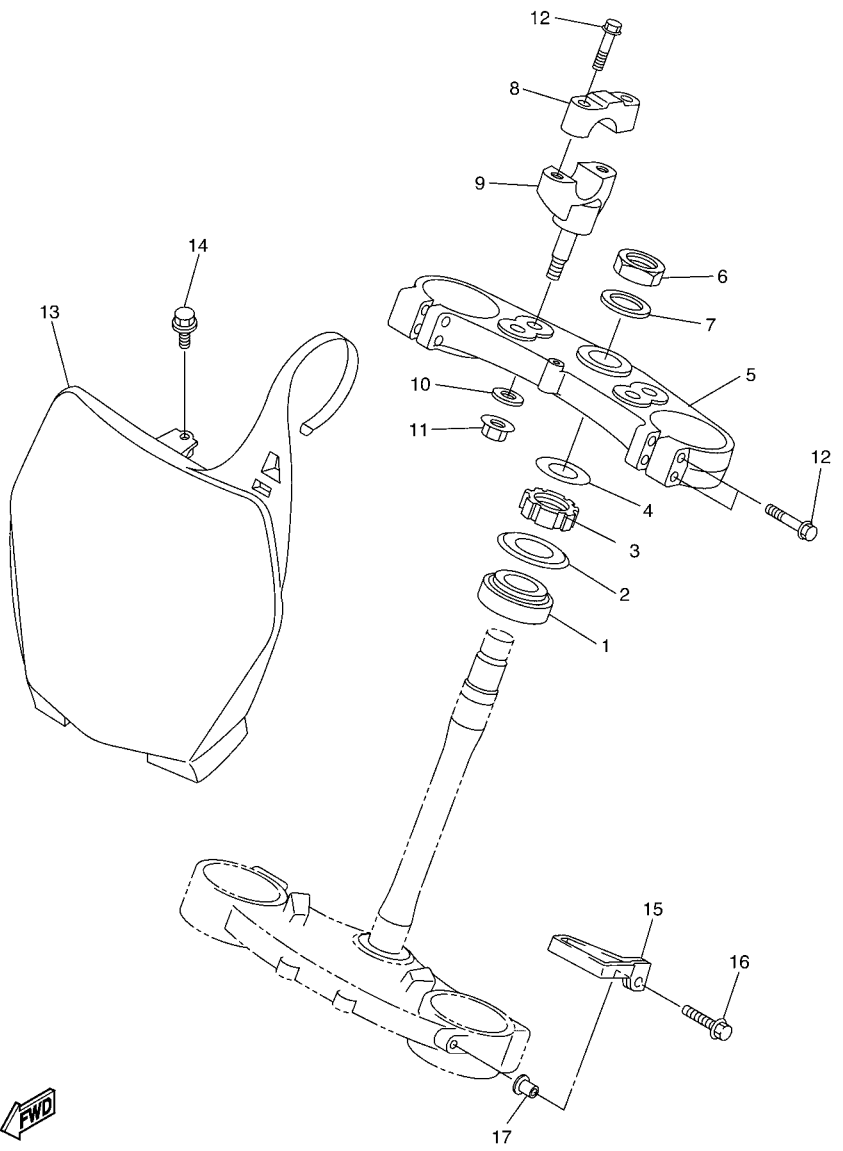
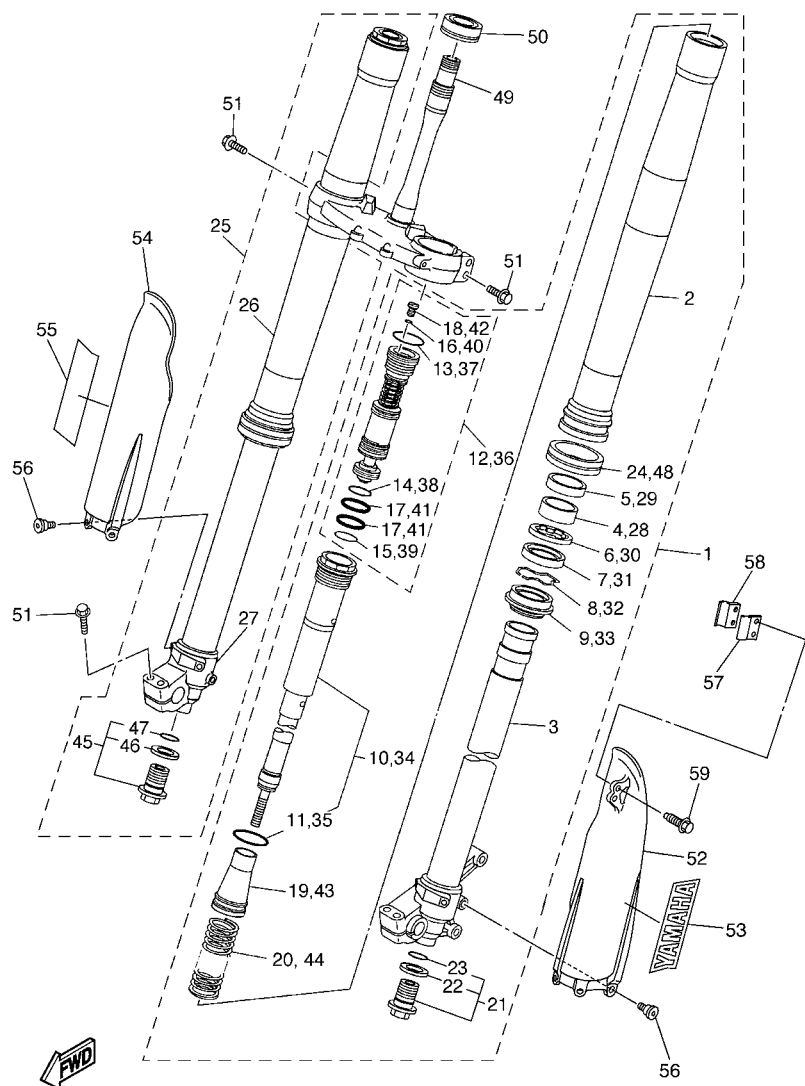

FIG. 25 STEERING

REF. NO.	PART NO.	DESCRIPTION	5XCR	5XCS	5XCT	5XCU	REMARKS
1	93332-00068	BEARING	1	1	1	1	
2	4EW-23416-00	COVER, BALL RACE 2	1	1	1	1	
3	90179-28013	NUT	1	1	1	1	
4	90201-286K9	WASHER, PLATE (T1.0)	1	1	1	1	
5	17D-23435-00	CROWN, HANDLE	1	1	1	1	
6	90170-24003	NUT	1	1	1	1	
7	90201-24016	WASHER, PLATE	1	1	1	1	
8	5XC-23441-90	HOLDER, HANDLE UPPER	2	2	2	2	
9	5UM-23442-E0	HOLDER, HANDLE LOWER	2	2	2	2	
10	92902-10200	WASHER	2	2	2	2	
11	95602-10200	NUT, U FLANGE	2	2	2	2	
12	90105-08154	BOLT, FLANGE	8	8	8	8	
13	1C3-23485-61	PLATE, NUMBER	1	1	1	1	
14	90119-06151	BOLT, WITH WASHER	1	1	1	1	
15	5XE-23389-00	GUIDE, CABLE	1	1	1	1	
16	90105-06107	BOLT, FLANGE	1	1	1	1	
17	90387-06104	COLLAR	1	1	1	1	

FIG. 26 FRONT FORK



34P1100-H260

REF. NO.	PART NO.	DESCRIPTION	5XCR	5XCS	5XCT	5XCU	REMARKS
1	5XC-23102-R0	FRONT FORK ASSY (L.H)	1		1		
	5XC-23102-S0	FRONT FORK ASSY (L.H)		1		1	
2	5XC-23136-00	.TUBE, OUTER (RIGHT)	1	1	1	1	
3	5XC-23120-N0	.INNER TUBE COMP.2	1	1	1	1	
4	5XE-23171-L0	.PISTON, FRONT FORK	1	1	1	1	
5	5XE-23125-L0	.METAL, SLIDE 1	1	1	1	1	
6	5XC-23146-10	.WASHER, OIL SEAL	1	1	1	1	
7	1C3-23145-M0	.OIL SEAL	1	1	1	1	
8	5XE-23153-L0	.RING, SNAP	1	1	1	1	
9	5XE-23144-L0	.SEAL, DUST	1	1	1	1	
10	5XC-23170-R0	.CYLINDER COMP., FRONT FORK	1		1		
	5XC-23170-S0	.CYLINDER COMP., FRONT FORK		1		1	
11	1C3-23147-L0	..O-RING	1	1	1	1	
12	5XC-2316A-V0	.VALVE COMP.	1		1		
	5XC-2316A-W0	.VALVE COMP.		1		1	
13	1C3-23188-L0	..O-RING	1	1	1	1	
14	1C3-23188-N0	..O-RING	1	1	1	1	
15	1C3-23188-P0	..O-RING	1	1	1	1	
16	1C3-23188-R0	..O-RING	1	1	1	1	
17	1AE-23147-00	..O-RING	2	2	2	2	
18	1C3-23190-L0	..AIR VALVE COMP.	1	1	1	1	
19	1C3-23142-L0	.SEAT, SPRING UPPER	1	1	1	1	
20	5XC-23141-N0	.SPRING, FRONT FORK(K=4.4N/MM)	1		1		
	2S2-23141-M1	.SPRING, FRONT FORK(K=4.5N/MM)		1		1	
21	5XC-23111-00	.BOLT, CAP	1	1	1	1	
22	2HH-23158-L0	..GASKET	1	1	1	1	
23	276-23114-00	..GASKET	1	1	1	1	

FIG. 26 FRONT FORK

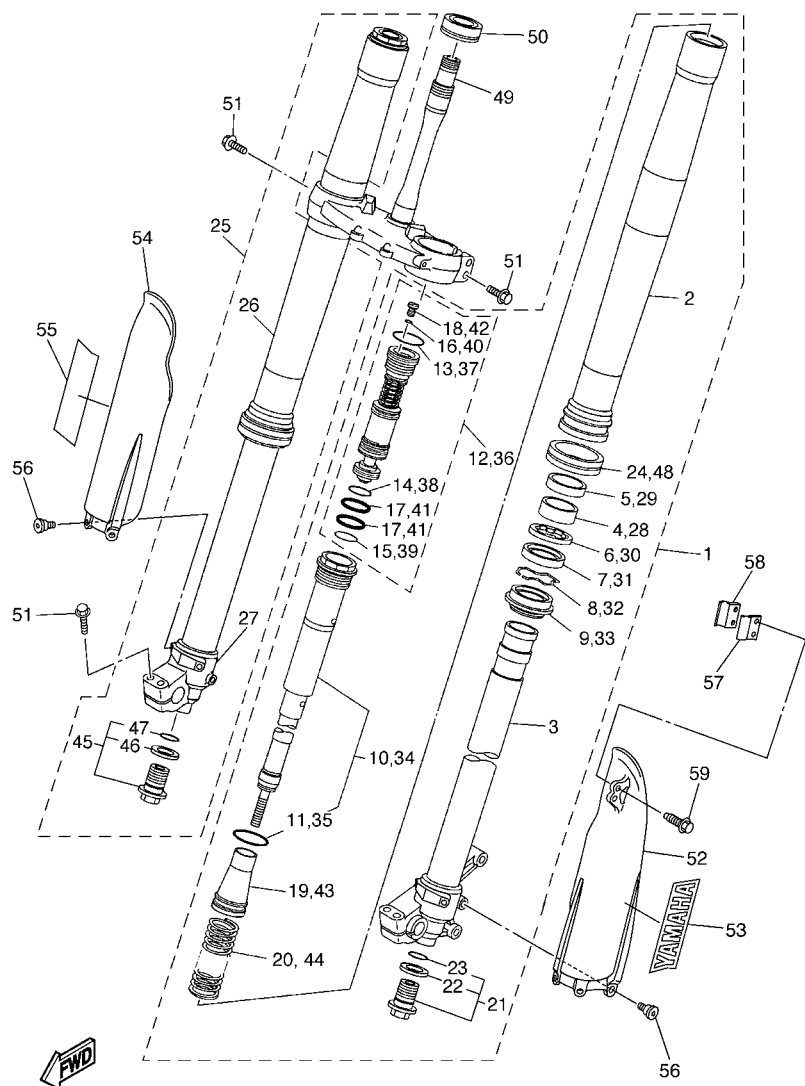

34P1100-H260

REF. NO.	PART NO.	DESCRIPTION	5XCR	5XCS	5XCT	5XCU	REMARKS
24	5XC-2314F-00	.PROTECTOR GUIDE COMP, 1	1	1	1	1	
25	5XC-23103-R0	FRONT FORK ASSY (R.H)	1		1		
	5XC-23103-S0	FRONT FORK ASSY (R.H)		1		1	
26	5XC-23136-00	.TUBE, OUTER (RIGHT)	1	1	1	1	
27	5XC-23110-N0	.INNER TUBE COMP.1	1	1	1	1	
28	5XE-23171-L0	.PISTON, FRONT FORK	1	1	1	1	
29	5XE-23125-L0	.METAL, SLIDE 1	1	1	1	1	
30	5XC-23146-10	.WASHER, OIL SEAL	1	1	1	1	
31	1C3-23145-M0	.OIL SEAL	1	1	1	1	
32	5XE-23153-L0	.RING, SNAP	1	1	1	1	
33	5XE-23144-L0	.SEAL, DUST	1	1	1	1	
34	5XC-23170-R0	.CYLINDER COMP., FRONT FORK	1			1	
	5XC-23170-S0	.CYLINDER COMP., FRONT FORK		1		1	
35	1C3-23147-L0	..O-RING	1	1	1	1	
36	5XC-2316A-V0	.VALVE COMP.	1			1	
	5XC-2316A-W0	.VALVE COMP.		1		1	
37	1C3-23188-L0	..O-RING	1	1	1	1	
38	1C3-23188-N0	..O-RING	1	1	1	1	
39	1C3-23188-P0	..O-RING	1	1	1	1	
40	1C3-23188-R0	..O-RING	1	1	1	1	
41	1AE-23147-00	..O-RING	2	2	2	2	
42	1C3-23190-L0	..AIR VALVE COMP.	1	1	1	1	
43	1C3-23142-L0	.SEAT, SPRING UPPER	1	1	1	1	
44	5XC-23141-N0	.SPRING, FRONT FORK(K=4.4N/MM)	1			1	
	2S2-23141-M1	.SPRING, FRONT FORK(K=4.5N/MM)		1		1	
45	5XC-23111-00	.BOLT, CAP	1	1	1	1	
46	2HH-23158-L0	..GASKET	1	1	1	1	

FIG. 26 FRONT FORK

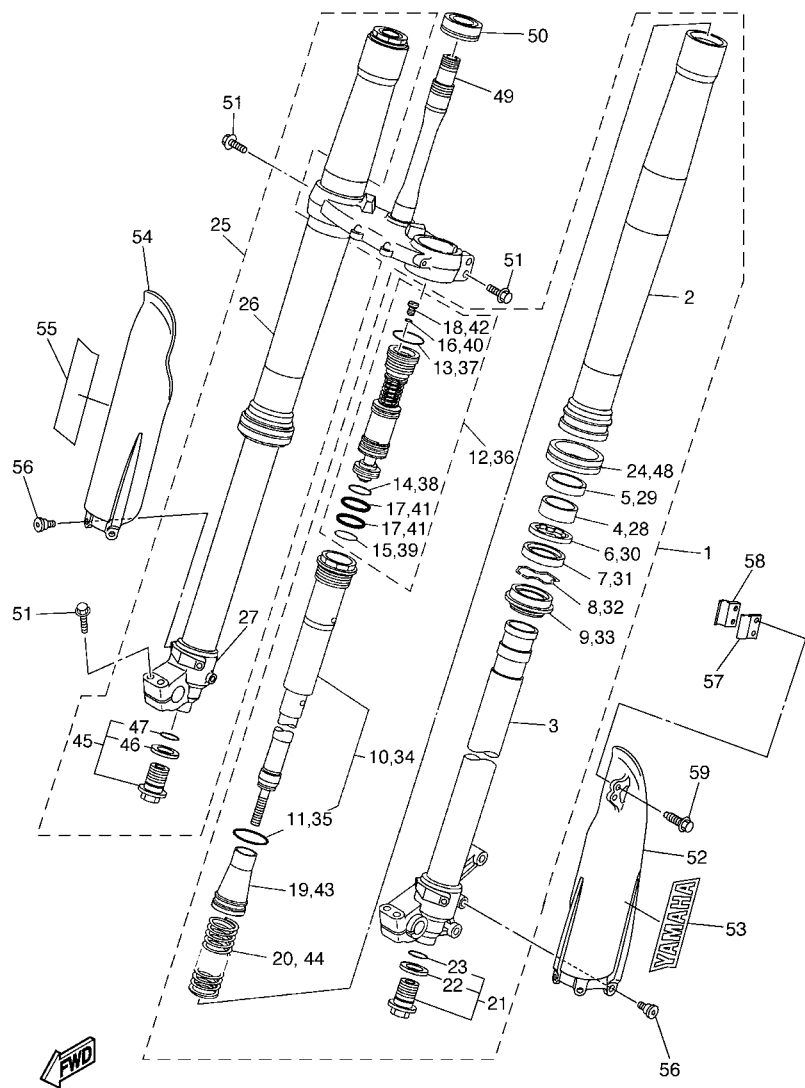

34P1100-H260

REF. NO.	PART NO.	DESCRIPTION	5XCR	5XCS	5XCT	5XCU	REMARKS
47	276-23114-00	..GASKET	1	1	1	1	
48	5XC-2314F-00	.PROTECTOR GUIDE COMP, 1	1	1	1	1	
49	5XC-23340-P0	UNDER BRACKET COMP.	1	1	1	1	
50	93332-00081	BEARING	1	1	1	1	
51	90105-08154	BOLT, FLANGE	8	8	8	8	
52	5XC-2315H-00	PROTECTOR 1	1	1	1	1	
53	4XL-2153A-10	EMBLEM, YAMAHA	1	1	1	1	
54	5XC-2315J-00	PROTECTOR 2	1	1	1	1	
55	4XL-2153A-10	EMBLEM, YAMAHA	1	1	1	1	
56	90109-06232	BOLT	6	6	6	6	
57	17D-23466-00	CLAMP	1	1	1	1	
58	17D-23467-00	CLAMP	1	1	1	1	
59	90105-06178	BOLT, FLANGE	2	2	2	2	

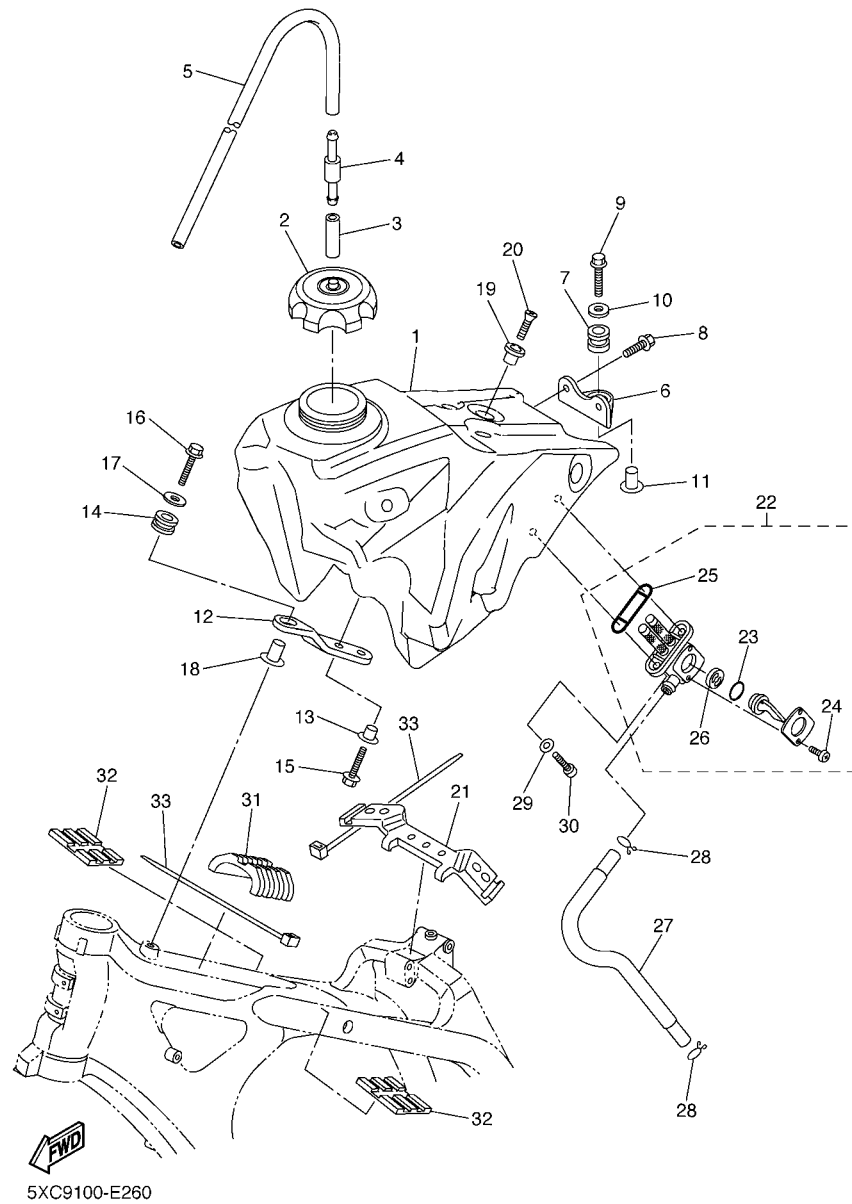
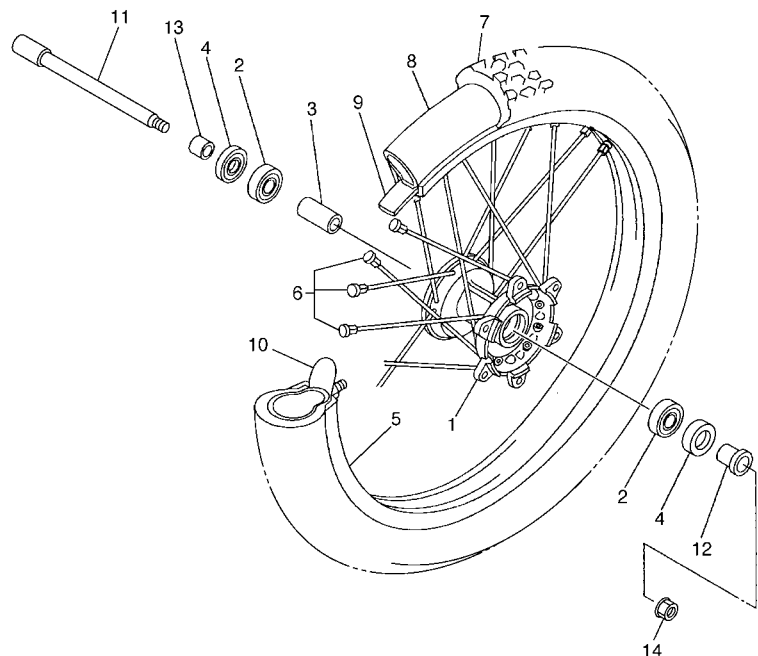

FIG. 27 FUEL TANK

REF. NO.	PART NO.	DESCRIPTION	5XCR	5XCS	5XCT	5XCU	REMARKS
1	2S2-24110-70	FUEL TANK COMP.	1	1	1	1	
2	5NY-24610-00	CAP ASSY	1	1	1	1	
3	90445-09220	HOSE (L30)	1	1	1	1	
4	3XJ-24380-00	PIPE JOINT ASSY	1	1	1	1	
5	90445-09251	HOSE (L350)	1	1	1	1	
6	5XE-24144-00	HOLDER, DAMPER	1	1	1	1	
7	90480-18549	GROMMET	1	1	1	1	
8	90105-06107	BOLT, FLANGE	2	2	2	2	
9	90105-06111	BOLT, FLANGE	1	1	1	1	
10	90201-06570	WASHER, PLATE	1	1	1	1	
11	3JD-24186-00	WASHER, SPECIAL	1	1	1	1	
12	5UM-2419A-E0	HOLDER	1	1	1	1	
13	90387-06090	COLLAR	2	2	2	2	
14	5XC-24339-90	GROMMET	1	1	1	1	
15	90105-06107	BOLT, FLANGE	2	2	2	2	
16	90105-06111	BOLT, FLANGE	1	1	1	1	
17	90201-06570	WASHER, PLATE	1	1	1	1	
18	90387-06065	COLLAR	1	1	1	1	
19	4EW-2412F-00	BRACKET, SEAT	1	1	1	1	
20	98702-06025	SCREW, FLAT HEAD	1	1	1	1	
21	5XC-24181-90	DAMPER, LOCATING 1	1	1	1	1	
22	4JT-24500-10	FUEL COCK ASSY 1	1	1	1	1	
23	3AJ-24534-01	.SEAL, COCK	1	1	1	1	
24	98502-03008	.SCREW, PAN HEAD	2	2	2	2	
25	4X8-24512-00	.O-RING	1	1	1	1	
26	3AC-24523-00	.VALVE PACKING	1	1	1	1	
27	5XC-24311-G0	PIPE, FUEL 1	1	1	1	1	

FIG. 29 FRONT WHEEL



REF. NO.	PART NO.	DESCRIPTION	5XCR	5XCS	5XCT	5XCU	REMARKS
1	5NY-25111-00	HUB, FRONT	1	1	1	1	
2	93306-90409	BEARING	2	2	2	2	
3	5NY-25117-00	SPACER, BEARING	1	1	1	1	
4	93102-26468	OIL SEAL	2	2	2	2	
5	94416-21034	RIM (1.60-21)	1	1	1	1	UR FOR DPBSE
	94416-21041	RIM (1.60-21)	1	1	1	1	UR FOR PWS1
6	5NY-25104-00	SPOKE SET, FRONT	1	1	1	1	
7	94108-21027	TIRE	1			1	BRIDGESTONE
	*	TIRE (80/100-21 51R MST)		1			LM PIRELLI
	*	TIRE (80/100-21 51M D742FA)			1		LM DUNLOP
8	94209-21229	TUBE (80/100-21 M/C TR4)	1			1	BRIDGESTONE
	*	TUBE (80/100-21)		1			LM PIRELLI
	*	TUBE (80/100-21 M/C TR4)			1		LM DUNLOP
9	94330-21084	BAND,RIM (1.60-21)	1			1	BRIDGESTONE
	*	BAND, RIM (80/100-21)		1			LM PIRELLI
	*	BAND, RIM (22-21)			1		LM DUNLOP
10	5SF-25394-00	SPACER, BEAD	1	1	1	1	
11	5XC-25181-G0	AXLE, WHEEL	1	1	1	1	
12	5XC-25183-G0	COLLAR, WHEEL	1	1	1	1	
13	5XC-25186-G0	COLLAR, WHEEL	1	1	1	1	
14	90179-16011	NUT	1	1	1	1	



5XD5100-D280

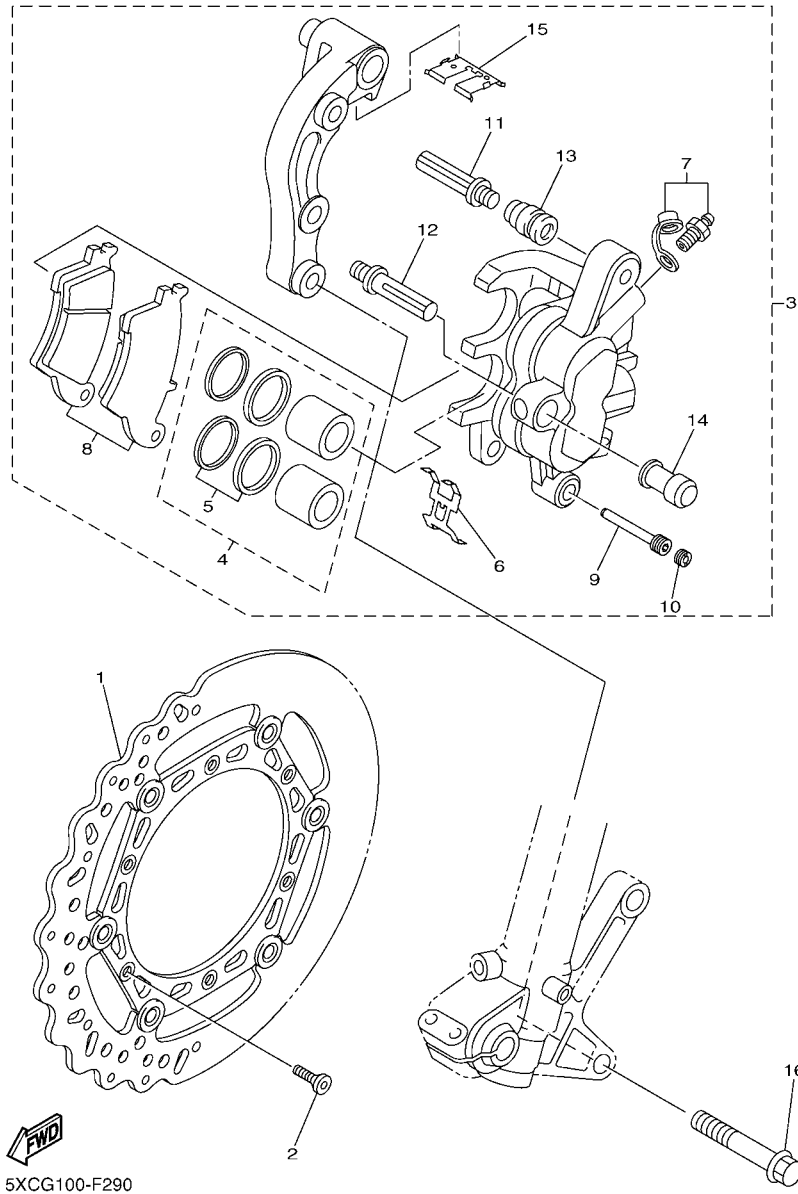
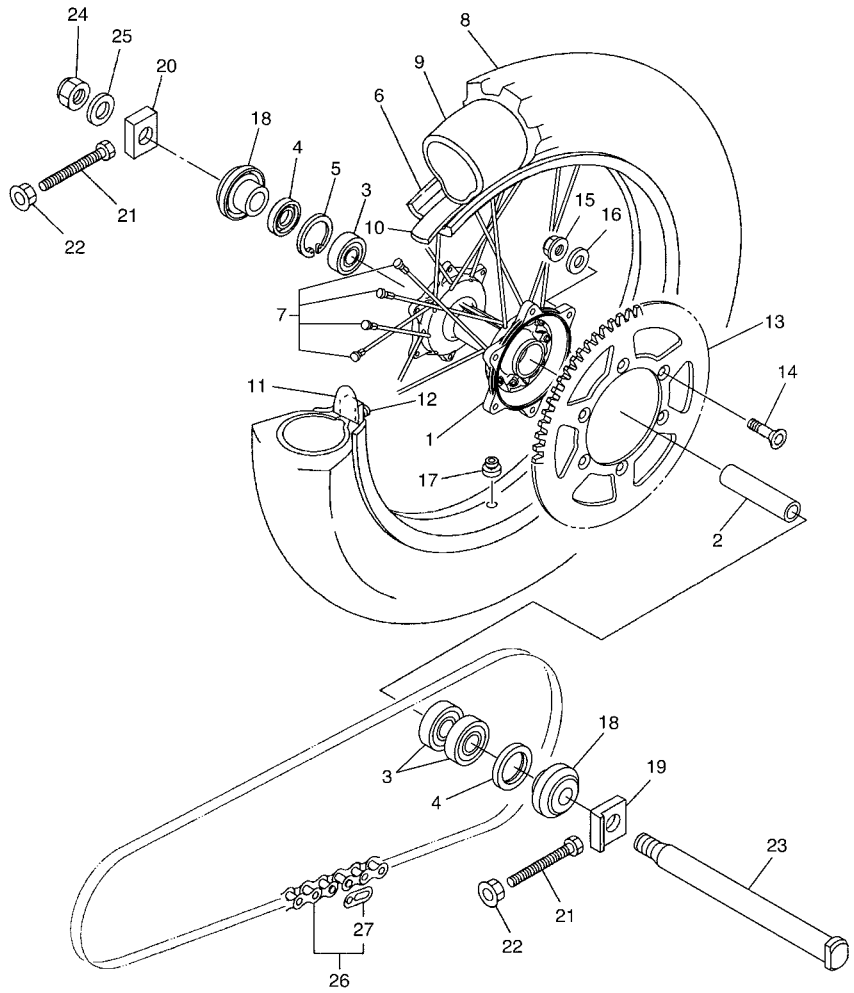

FIG. 30 FRONT BRAKE CALIPER

REF. NO.	PART NO.	DESCRIPTION	5XCR	5XCS	5XCT	5XCU	REMARKS
1	5XC-2581T-G0	DISK BRAKE ASSY	1	1	1	1	
2	90151-06051	SCREW, COUNTERSUNK	6	6	6	6	
3	5XC-2580T-G0	CALIPER ASSY (LEFT)	1	1	1	1	
4	5XC-W0057-00	.PISTON ASSY, CALIPER	1	1	1	1	
5	5KM-W0047-10	..CALIPER SEAL KIT	1	1	1	1	
6	5DH-25919-00	..SUPPORT, PAD	1	1	1	1	
7	1UY-W0048-50	.BLEED SCREW KIT	1	1	1	1	
8	5XC-W0045-00	.BRAKE PAD KIT	1	1	1	1	
9	5DH-25933-00	.PIN, PAD	1	1	1	1	
10	5DH-25916-00	.PLUG	1	1	1	1	
11	3SP-25926-51	.BOLT	1	1	1	1	
12	3SP-25914-51	.PIN, SLIDE	1	1	1	1	
13	3JD-25917-00	.BOOT, CALIPER	1	1	1	1	
14	1UY-25937-51	.BOOT 2	1	1	1	1	
15	5XC-25849-G0	.RETAINER, CALIPER	1	1	1	1	
16	90105-08137	BOLT, FLANGE	2	2	2	2	



34P1100-H310

FIG. 31 REAR WHEEL

REF. NO.	PART NO.	DESCRIPTION	5XCR	5XCS	5XCT	5XCU	REMARKS
1	17D-25311-00	HUB, REAR	1	1	1	1	
2	17D-25317-00	SPACER, BEARING	1	1	1	1	
3	93306-90510	BEARING	3	3	3	3	
4	93102-32337	OIL SEAL	2	2	2	2	
5	99009-42700	CIRCLIP	1	1	1	1	
6	94418-19026	RIM (1.85-19)	1	1	1	1	UR FOR DPBSE
	94418-19035	RIM (1.85-19)	1	1	1	1	UR FOR PWS1
7	34P-25304-00	SPOKE SET, REAR	1	1	1	1	
8	94110-19019	TIRE (100/90-19 57M M404)	1			1	BRIDGESTONE
*		TIRE (100/90-19 57M NHS)				1	LM PIRELLI
*		TIRE (100/90-19 57M D756G)				1	LM DUNLOP
9	94210-19222	TUBE (100/90-19 M/C TR4)	1			1	BRIDGESTONE
*		TUBE (110/90-19)				1	LM PIRELLI
*		TUBE (100/90-19 M/C TR4 BTL)				1	LM DUNLOP
10	94316-19156	BAND, RIM (1.85-19)	1			1	BRIDGESTONE
*		BAND, RIM (3.50-18)				1	LM METZELER
*		BAND, RIM (22-19)				1	LM DUNLOP
11	4XM-25394-00	SPACER, BEAD	1	1	1	1	
12	4XM-25364-00	DAMPER	1	1	1	1	
13	1C3-25449-00	SPROCKET, DRIVEN (49T)	1				STD
	1C3-25451-00	SPROCKET, DRIVEN (51T)				1	STD
	1C3-25447-00	SPROCKET, DRIVEN (47T)	1	1	1	1	AP
	1C3-25448-00	SPROCKET, DRIVEN (48T)	1	1	1	1	AP
	1C3-25450-00	SPROCKET, DRIVEN (50T)	1	1	1	1	AP
	1C3-25452-00	SPROCKET, DRIVEN (52T)	1	1	1	1	AP
14	90109-08078	BOLT	6	6	6	6	
15	90185-08008	NUT, SELF-LOCKING	6	6	6	6	

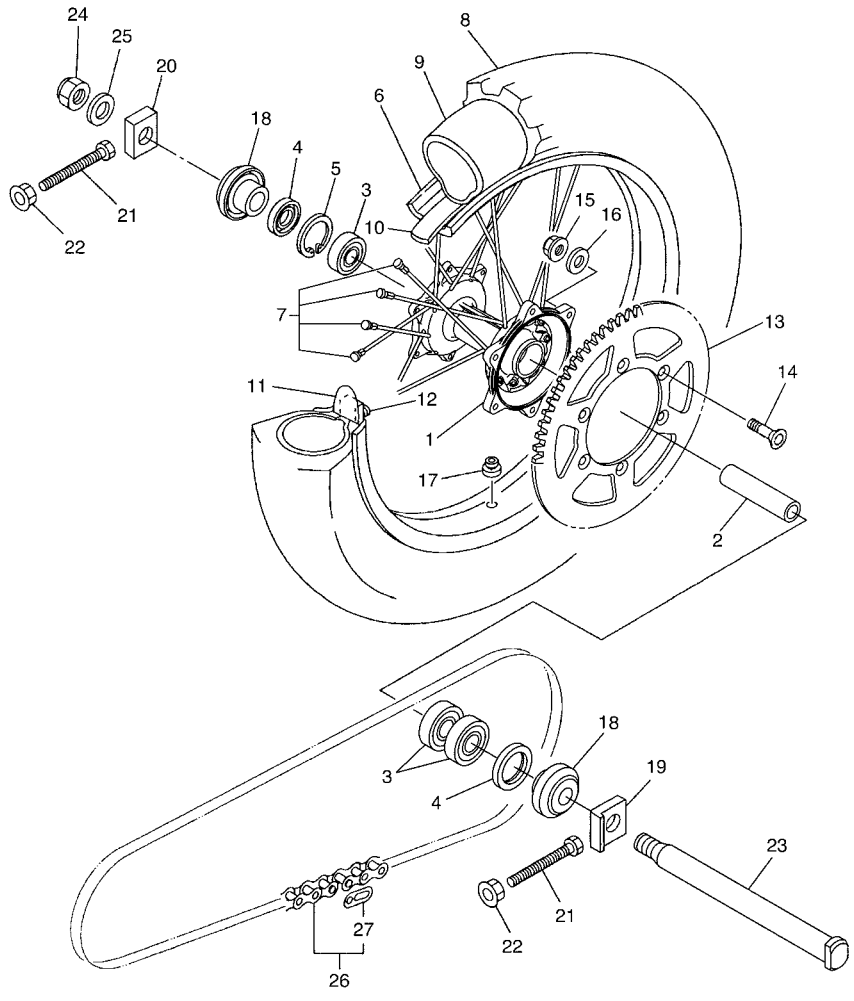

34P1100-H310

FIG. 31 REAR WHEEL

REF. NO.	PART NO.	DESCRIPTION	5XCR	5XCS	5XCT	5XCU	REMARKS
16	90201-08048	WASHER, PLATE	6	6	6	6	
17	90480-08608	GROMMET	1	1	1	1	
18	17D-2530S-00	COLLAR ASSY	2	2	2	2	
19	17D-25388-00	PULLER, CHAIN 1	1	1	1	1	
20	17D-25389-00	PULLER, CHAIN 2	1	1	1	1	
21	90101-08006	BOLT	2	2	2	2	
22	90179-08019	NUT	2	2	2	2	
23	17D-25381-00	AXLE, WHEEL	1	1	1	1	
24	90185-22009	NUT, SELF-LOCKING	1	1	1	1	
25	90201-22021	WASHER, PLATE	1	1	1	1	
26	9Y582-28111	CHAIN (DID520DMA2-114LL)	1				
	9Y582-28113	CHAIN (DID520DMA2-114LL)		1	1	1	
27	94682-28001	.JOINT, CHAIN (DID520DM G&B-RJ)	1	1	1	1	

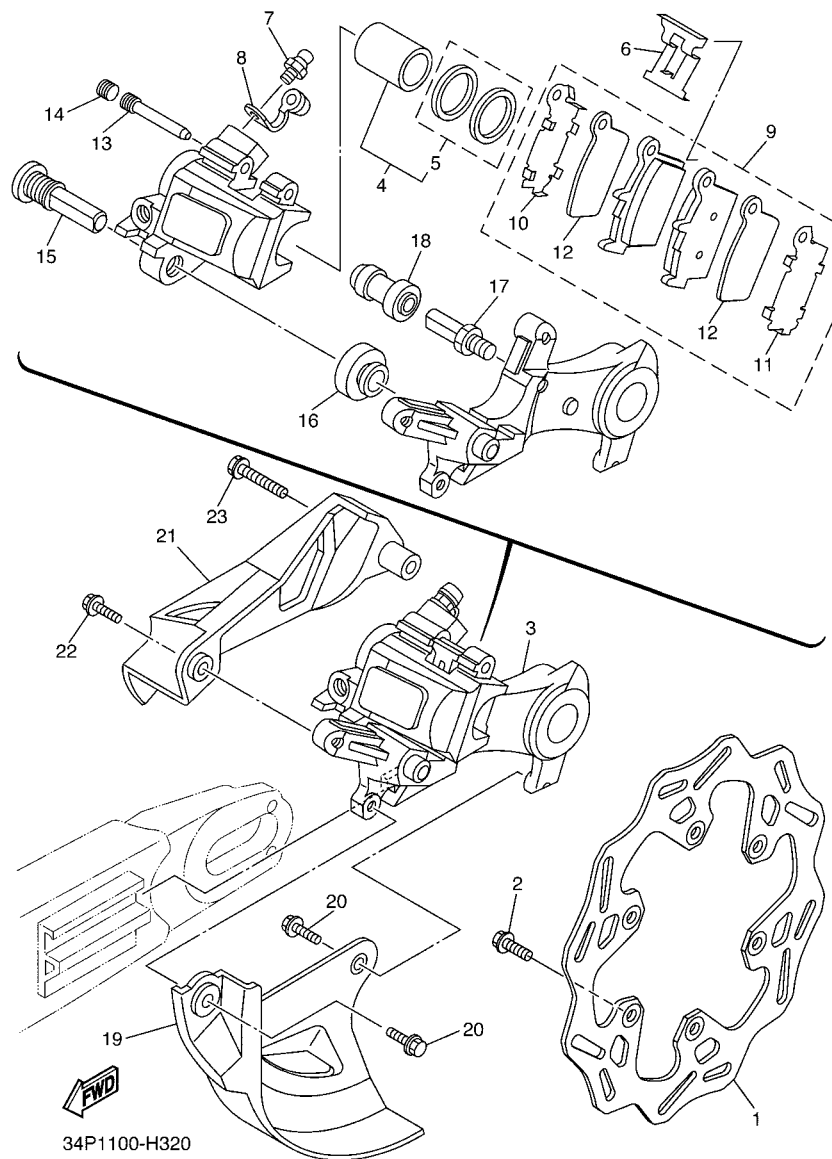
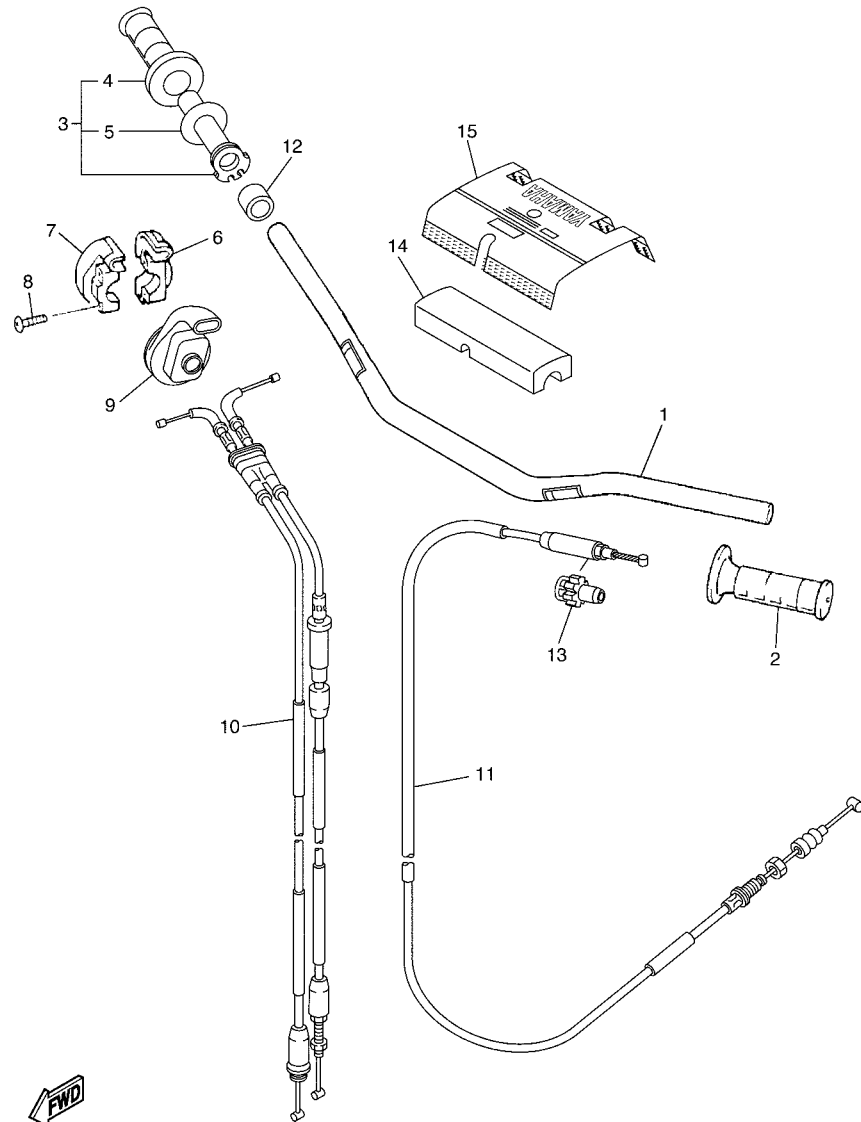

FIG. 32 REAR BRAKE CALIPER

REF. NO.	PART NO.	DESCRIPTION	5XCR	5XCS	5XCT	5XCU	REMARKS
1	2S2-2582W-70	DISK, REAR BRAKE 2	1	1	1	1	
2	90105-06156	BOLT, FLANGE	6	6	6	6	
3	17D-2580W-01	CALIPER ASSY, REAR 2	1		1	1	
	17D-2580W-11	CALIPER ASSY, REAR 2		1			
4	5UN-W0057-50	.PISTON ASSY, CALIPER	1	1	1	1	
5	5UN-W0047-50	..CALIPER SEAL KIT	1	1	1	1	
6	5DH-25919-50	.SUPPORT, PAD	1	1	1	1	
7	1UY-25824-51	.SCREW, BLEED	1	1	1	1	
8	1UY-25825-51	.CAP	1	1	1	1	
9	1C3-W0046-50	.BRAKE PAD KIT 2	1		1	1	
	1C3-W0046-B0	.BRAKE PAD KIT 2		1			
10	5UN-25828-60	..SHIM, CALIPER	1	1	1	1	
11	5UN-25827-60	..SHIM, CALIPER	1	1	1	1	
12	5UN-22898-60	..INSULATOR, HEAT	2	2	2	2	
13	8CR-25924-00	.PIN, PAD	1	1	1	1	
14	5DH-25916-00	.PLUG	1	1	1	1	
15	5DH-25914-50	.PIN, SLIDE	1	1	1	1	
16	3JD-25917-00	.BOOT, CALIPER	1	1	1	1	
17	5UN-25914-00	.PIN, SLIDE	1	1	1	1	
18	1UY-25937-51	.BOOT 2	1	1	1	1	
19	1C3-25718-50	PROTECTOR, DISK BRAKE	1	1	1	1	
20	90105-06110	BOLT, FLANGE	2	2	2	2	
21	1C3-27491-50	PROTECTOR	1	1	1	1	
22	90105-06107	BOLT, FLANGE	1	1	1	1	
23	90105-06111	BOLT, FLANGE	1	1	1	1	



34P1100-H330

FIG. 33 STEERING HANDLE & CABLE

REF. NO.	PART NO.	DESCRIPTION	5XCR	5XCS	5XCT	5XCU	REMARKS
1	5XC-26111-L0	HANDLEBAR	1	1	1	1	
2	4GY-26241-00	GRIP	1	1	1	1	
3	5TJ-26240-C0	GRIP ASSY	1	1	1	1	
4	4GY-26242-00	.GRIP (RIGHT)	1	1	1	1	
5	3Y1-26249-00	.RING, LEAF	1	1	1	1	
6	5BE-26281-00	CAP, GRIP UPPER	1	1	1	1	
7	5BE-26282-00	CAP, GRIP UNDER	1	1	1	1	
8	98502-05020	SCREW, PAN HEAD	2	2	2	2	
9	5SF-26287-10	COVER, CAP GRIP	1	1	1	1	
10	5XC-26302-R0	THROTTLE CABLE ASSY	1	1	1	1	
11	5XC-26335-R0	CABLE, CLUTCH	1	1	1	1	
12	90387-225N2	COLLAR	1	1	1	1	
13	34P-26342-00	BOOT, CABLE	1	1	1	1	
14	17D-26124-00	PROTECTOR, HANDLEBAR	1	1	1	1	
15	5XC-26143-L0	COVER, HANDLEBAR UPPER 1	1	1	1	1	UR FOR DPBSE
	5XC-26143-M0	COVER, HANDLEBAR UPPER 1	1	1	1	1	UR FOR PWS1

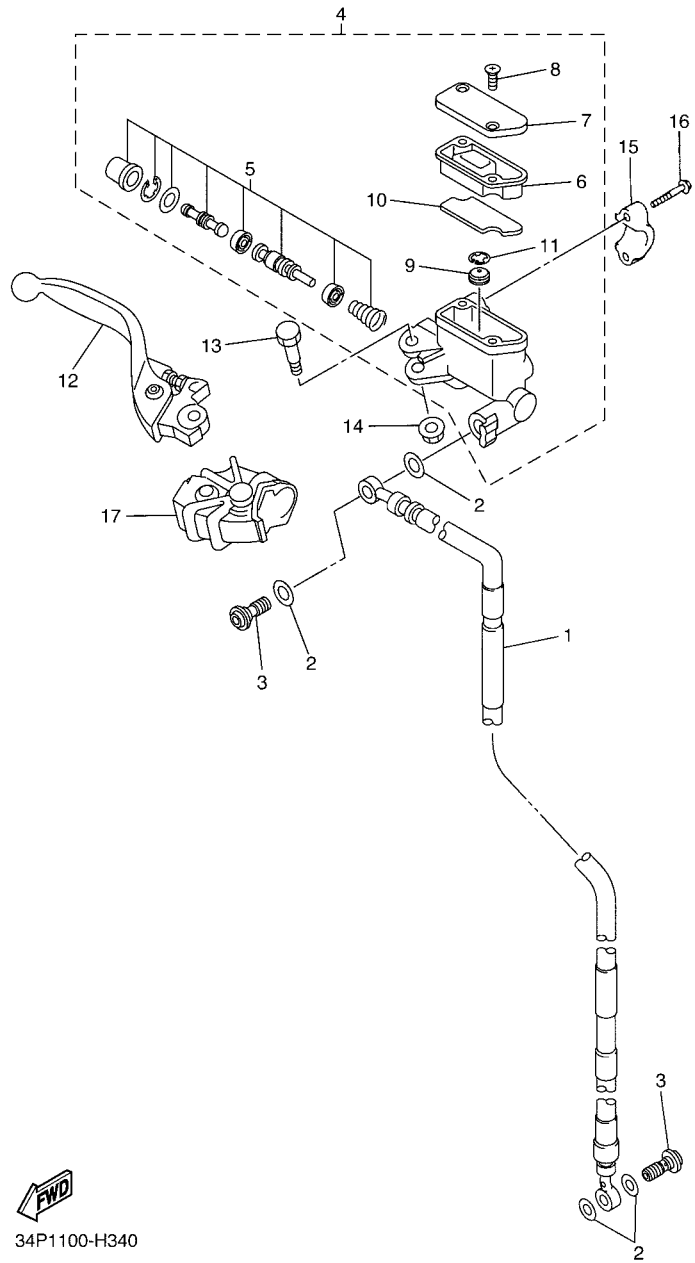

FWD
34P1100-H340

FIG. 34 FRONT MASTER CYLINDER

REF. NO.	PART NO.	DESCRIPTION	5XCR	5XCS	5XCT	5XCU	REMARKS
1	5XC-25872-L0	HOSE, BRAKE 1	1	1	1	1	
2	90430-10005	GASKET	4	4	4	4	
3	90401-10172	BOLT, UNION	2	2	2	2	
4	5XC-W2587-00	MASTER CYLINDER SUB ASSY	1	1	1	1	
5	5XC-W0041-00	.CYLINDER KIT, MASTER	1	1	1	1	
6	5XC-25854-G0	.GASKET, DIAPHRAGM	1	1	1	1	
7	5XC-25852-G0	.CAP, RESERVOIR	1	1	1	1	
8	98706-04012	.SCREW, FLAT HEAD	2	2	2	2	
9	5CG-25715-00	.SEPARATOR ASSY	1	1	1	1	
10	5XC-25853-G0	.FLOAT, RESERVOIR	1	1	1	1	
11	5CG-2585G-00	.CIRCLIP	1	1	1	1	
12	5XC-83922-L0	LEVER 2	1	1	1	1	
13	5MV-2589F-00	BOLT, LEVER	1	1	1	1	
14	95701-06500	NUT, WITH WASHER	1	1	1	1	
15	5MV-25867-00	BRACKET, MASTER CYLINDER	1	1	1	1	
16	5MV-25833-00	BOLT, FITTING	2	2	2	2	
17	5XC-26372-G0	COVER, HANDLE LEVER 1	1	1	1	1	

FIG. 35 STAND & FOOTREST

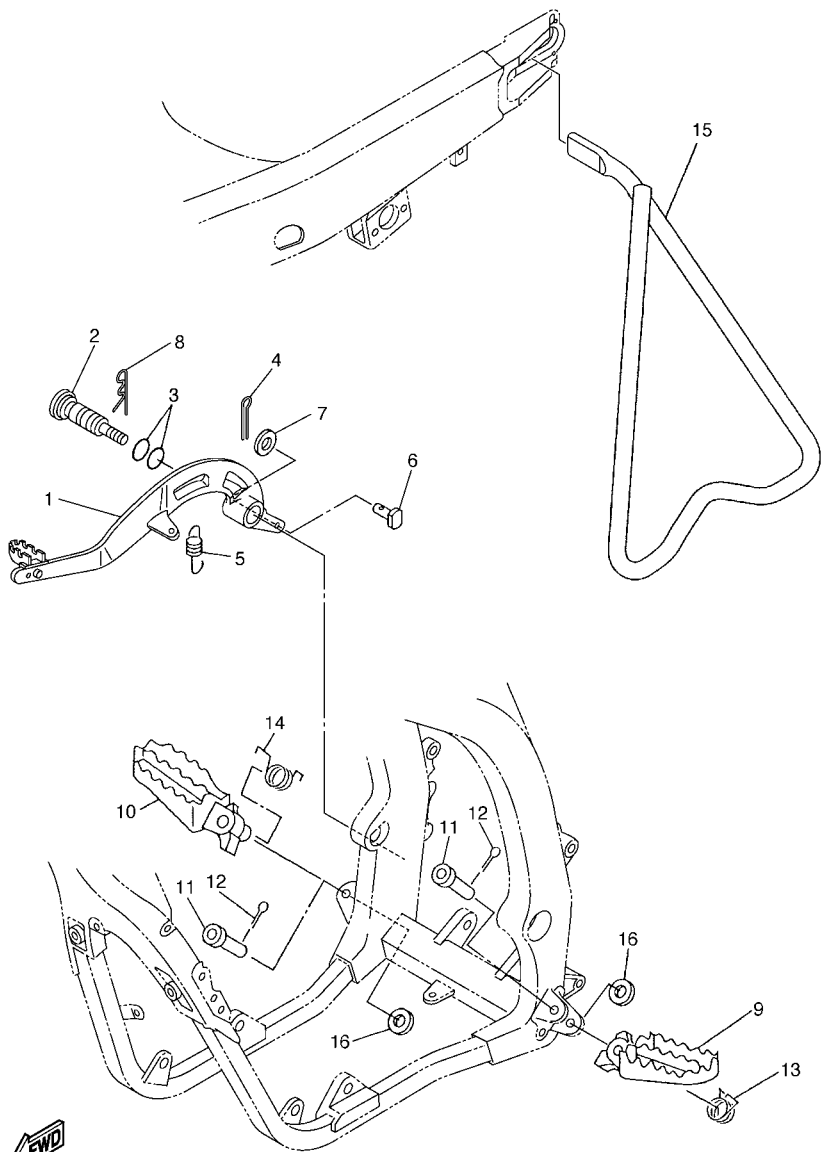

5XC9100-E340

REF. NO.	PART NO.	DESCRIPTION	5XCR	5XCS	5XCT	5XCU	REMARKS
1	5XC-27200-A0	PEDAL, BRAKE	1	1	1	1	
2	5XC-27217-90	BOLT	1	1	1	1	
3	93210-11073	O-RING	2	2	2	2	
4	91402-20012	PIN, COTTER	1	1	1	1	
5	90506-16007	SPRING, TENSION	1	1	1	1	
6	90240-08120	PIN, CLEVIS	1	1	1	1	
7	90201-08044	WASHER, PLATE	1	1	1	1	
8	90468-16001	CLIP	1	1	1	1	
9	5XC-27411-M1	FOOTREST 1	1	1	1	1	
10	5XC-27421-M1	FOOTREST 2	1	1	1	1	
11	90240-10004	PIN, CLEVIS	2	2	2	2	
12	91402-25015	PIN, COTTER	2	2	2	2	
13	90508-28015	SPRING, TORSION	1	1	1	1	
14	90508-28018	SPRING, TORSION	1	1	1	1	
15	34P-27311-00	STAND, SIDE	1	1	1	1	
16	90201-10032	WASHER, PLATE	2	2	2	2	

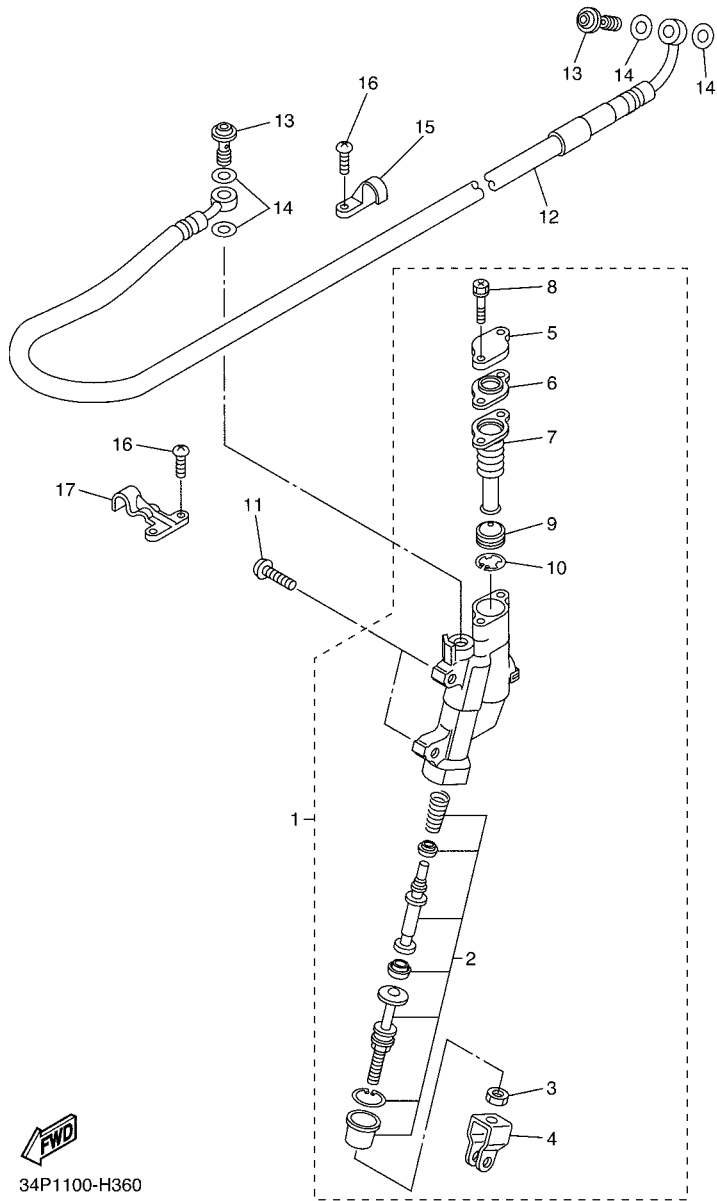

34P1100-H360

FIG. 36 REAR MASTER CYLINDER

REF. NO.	PART NO.	DESCRIPTION	5XCR	5XCS	5XCT	5XCU	REMARKS
1	17D-2583V-00	RR. MASTER CYLINDER ASSY.	1	1	1	1	
2	5UN-W0042-50	.CYLINDER KIT, MASTER	1	1	1	1	
3	5UN-27218-00	.NUT	1	1	1	1	
4	5UN-27222-00	.JOINT	1	1	1	1	
5	5UN-25852-50	.CAP, RESERVOIR	1	1	1	1	
6	5UN-2585B-00	.PLATE, DIAPHRAGM	1	1	1	1	
7	5UN-25854-00	.GASKET, DIAPHRAGM	1	1	1	1	
8	5UN-27217-00	.BOLT	2	2	2	2	
9	5CG-25715-00	.SEPARATOR ASSY	1	1	1	1	
10	5CG-2585G-00	.CIRCLIP	1	1	1	1	
11	90111-06116	BOLT,HEX. SOCKET BUTTON	2	2	2	2	
12	5XC-25873-L0	HOSE, BRAKE 2	1	1	1	1	
13	90401-10172	BOLT, UNION	2	2	2	2	
14	90430-10005	GASKET	4	4	4	4	
15	1C3-25886-50	HOLDER, BRAKE HOSE	1	1	1	1	
16	98502-05010	SCREW, PAN HEAD	4	4	4	4	
17	1C3-25876-50	HOLDER, BRAKE HOSE 2	1	1	1	1	

FIG. 37 GENERATOR

REF. NO.	PART NO.	DESCRIPTION	5XCR	5XCS	5XCT	5XCU	REMARKS
1	5XC-85560-10	BASE ASSY	1	1	1	1	
2	5TA-85550-00	ROTOR ASSY	1	1	1	1	
3	90149-06121	SCREW	3	3	3	3	
4	90179-12657	NUT	1	1	1	1	
5	90201-127E1	WASHER, PLATE	1	1	1	1	

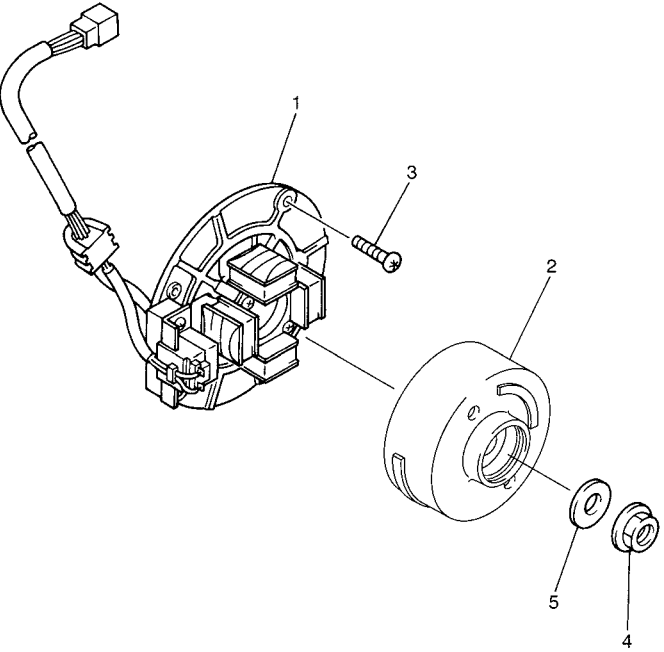

FWD
5TA1100-B360

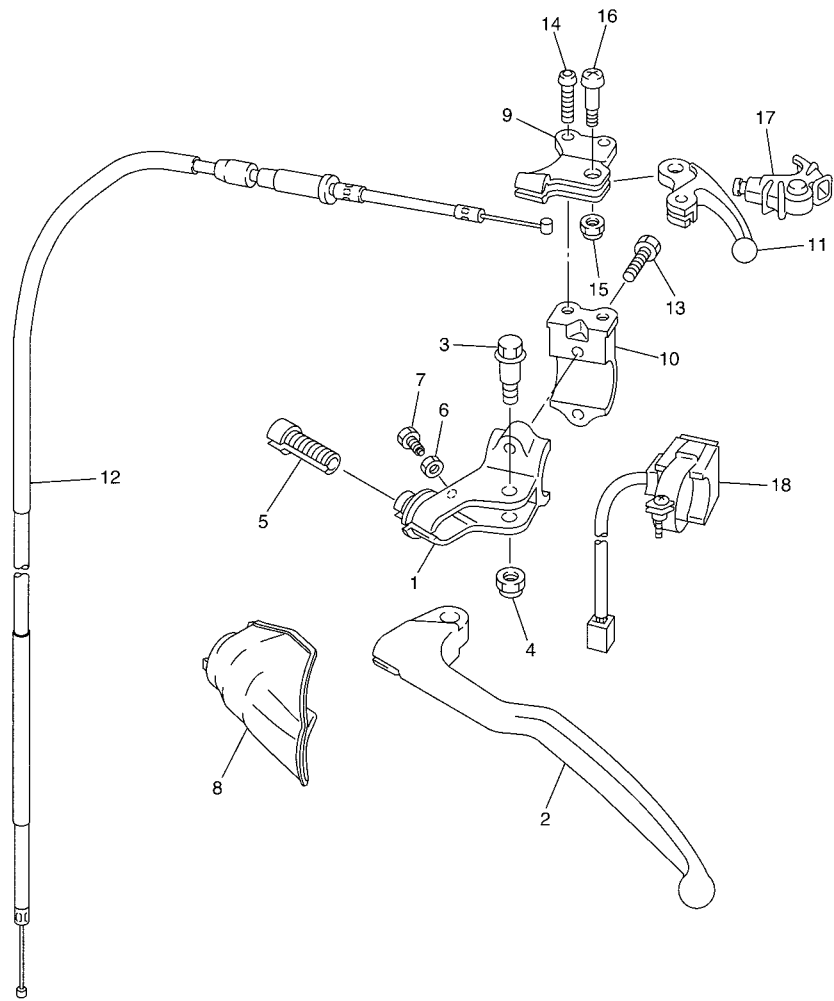

34P1100-H380

FIG. 38 HANDLE SWITCH & LEVER

REF. NO.	PART NO.	DESCRIPTION	5XCR	5XCS	5XCT	5XCU	REMARKS
1	17D-82911-00	HOLDER, LEVER 1	1	1	1	1	
2	17D-83912-00	LEVER 1	1	1	1	1	
3	90109-06034	BOLT	1	1	1	1	
4	5LP-84126-10	NUT, LENS FITTING	1	1	1	1	
5	17D-26337-00	BOLT, ADJUSTING	1	1	1	1	
6	95302-05700	NUT	1	1	1	1	
7	90101-05005	BOLT	1	1	1	1	
8	34P-26372-00	COVER, HANDLE LEVER 1	1	1	1	1	
9	5XD-82946-00	HOLDER, STARTER LEVER	1	1	1	1	
10	17D-82913-00	HOLDER, LEVER LOWER 1	1	1	1	1	
11	5TA-83941-00	LEVER, STARTER	1	1	1	1	
12	5XC-26334-R0	CABLE, STARTER 2	1	1	1	1	
13	95022-06020	BOLT, FLANGE	2	2	2	2	
14	92012-05012	BOLT, BUTTON HEAD	2	2	2	2	
15	95602-05100	NUT, U	1	1	1	1	
16	90149-05162	SCREW	1	1	1	1	
17	5TA-26339-00	BOOT	1	1	1	1	
18	1C3-83976-00	SWITCH, HANDLE 1	1	1	1	1	

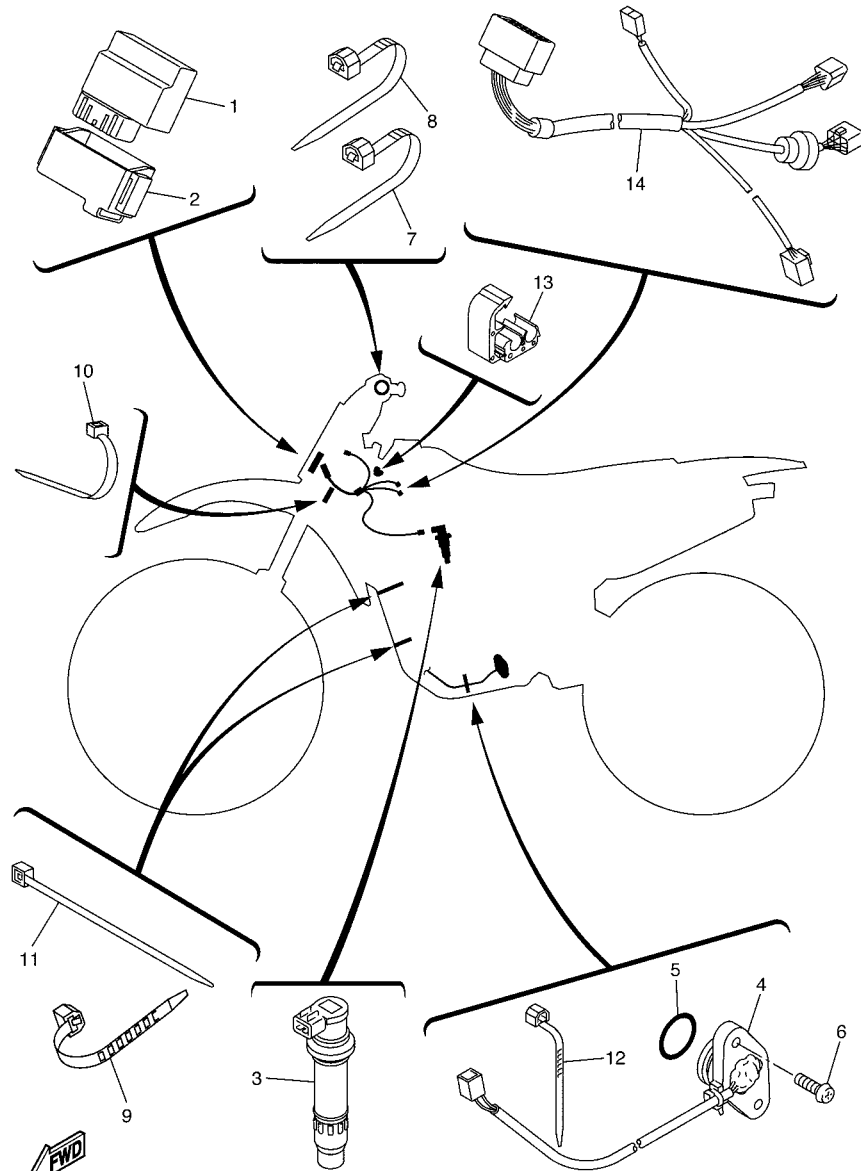

5XCR100-H390

FIG. 39 ELECTRICAL 1

REF. NO.	PART NO.	DESCRIPTION	5XCR	5XCS	5XCT	5XCU	REMARKS
1	5XC-85540-R0	C.D.I. UNIT ASSY	1				
	5XC-85540-S0	C.D.I. UNIT ASSY		1	1	1	
2	1C3-85546-00	BAND	1	1	1	1	
3	5UL-82310-10	IGNITION COIL ASSY	1	1	1	1	
4	5XC-82540-00	NEUTRAL SWITCH ASSY	1	1	1	1	
5	93210-21001	O-RING	1	1	1	1	
6	90154-05022	SCREW, BINDING	2	2	2	2	
7	90464-13077	CLAMP	1	1	1	1	
8	90464-13073	CLAMP	1	1	1	1	
9	90464-15195	CLAMP	1	1	1	1	
10	5Y9-12491-00	CLAMP 1	1	1	1	1	
11	90465-13275	CLAMP	4	4	4	4	
12	5Y9-12491-00	CLAMP 1	2	2	2	2	
13	90464-06004	CLAMP	1	1	1	1	
14	5XC-82509-00	WIRE, SUB LEAD	1	1	1	1	

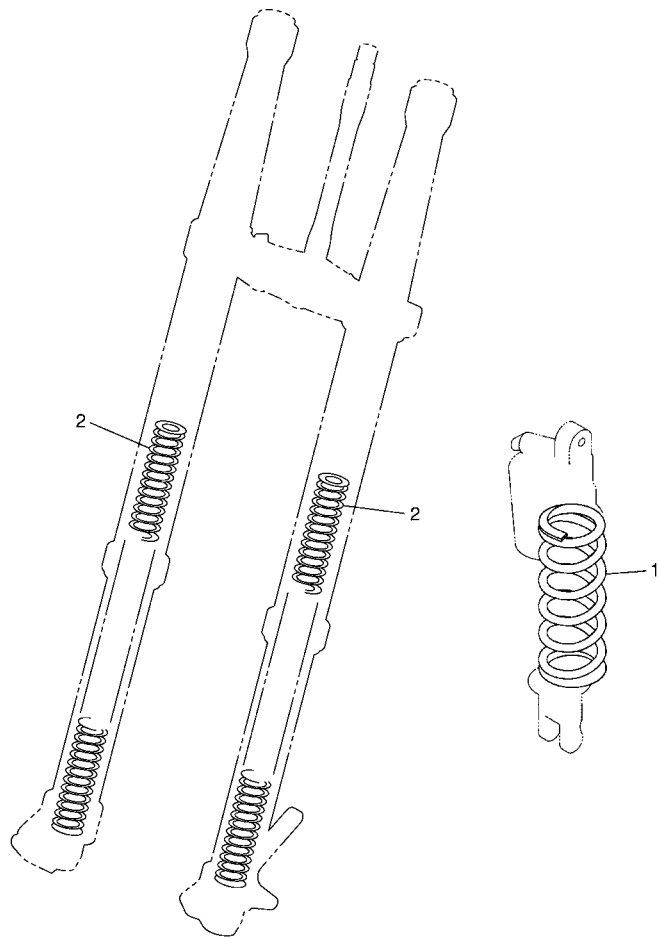

5XC9100-E390

FIG. 40 ALTERNATE FOR CHASSIS

REF. NO.	PART NO.	DESCRIPTION	5XCR	5XCS	5XCT	5XCU	REMARKS
1	5UN-22212-00	SPRING (K=42N/MM)	1	1	1	1	AP
	5UN-22212-10	SPRING (K=44N/MM)	1	1	1	1	AP
	5UN-22212-20	SPRING (K=46N/MM)	1	1	1	1	AP
	5UN-22212-30	SPRING (K=48N/MM)	1	1	1	1	AP
	5UN-22212-40	SPRING (K=50N/MM)	1	1	1	1	AP
	5UN-22212-60	SPRING (K=54N/MM)	1	1	1	1	AP
	5UN-22212-70	SPRING (K=56N/MM)	1	1	1	1	AP
	1C3-22212-00	SPRING (K=44N/MM)	1	1	1	1	AP
	1C3-22212-10	SPRING (K=46N/MM)	1	1	1	1	AP
	1C3-22212-20	SPRING (K=48N/MM)	1	1	1	1	AP
	1C3-22212-30	SPRING (K=50N/MM)	1	1	1	1	AP
	1C3-22212-40	SPRING (K=52N/MM)	1	1	1	1	AP
	1C3-22212-50	SPRING (K=54N/MM)	1	1	1	1	AP
	1C3-22212-60	SPRING (K=55.8N/MM)	1	1	1	1	AP
	5UN-22212-A0	SPRING (K=APPROX.44N/MM)	1	1	1	1	AP
	5UN-22212-B0	SPRING (K=APPROX.46N/MM)	1	1	1	1	AP
	5UN-22212-C0	SPRING (K=APPROX.48N/MM)	1	1	1	1	AP
	5UN-22212-D0	SPRING (K=APPROX.50N/MM)	1	1	1	1	AP
	5UN-22212-E0	SPRING (K=APPROX.52N/MM)	1	1	1	1	AP
	5UN-22212-F0	SPRING (K=APPROX.54N/MM)	1	1	1	1	AP
	5UN-22212-G0	SPRING (K=APPROX.56N/MM)	1	1	1	1	AP
2	1C3-23141-A1	SPRING, FRONT FORK(K=3.9N/MM)	2	2	2	2	AP
	1C3-23141-B1	SPRING, FRONT FORK(K=4.0N/MM)	2	2	2	2	AP
	1C3-23141-C1	SPRING, FRONT FORK(K=4.1N/MM)	2	2	2	2	AP
	1C3-23141-D1	SPRING, FRONT FORK(K=4.2N/MM)	2	2	2	2	AP
	1C3-23141-E1	SPRING, FRONT FORK(K=4.3N/MM)	2	2	2	2	AP
	1C3-23141-H1	SPRING, FRONT FORK(K=4.6N/MM)	2	2	2	2	AP

FIG. 40 ALTERNATE FOR CHASSIS

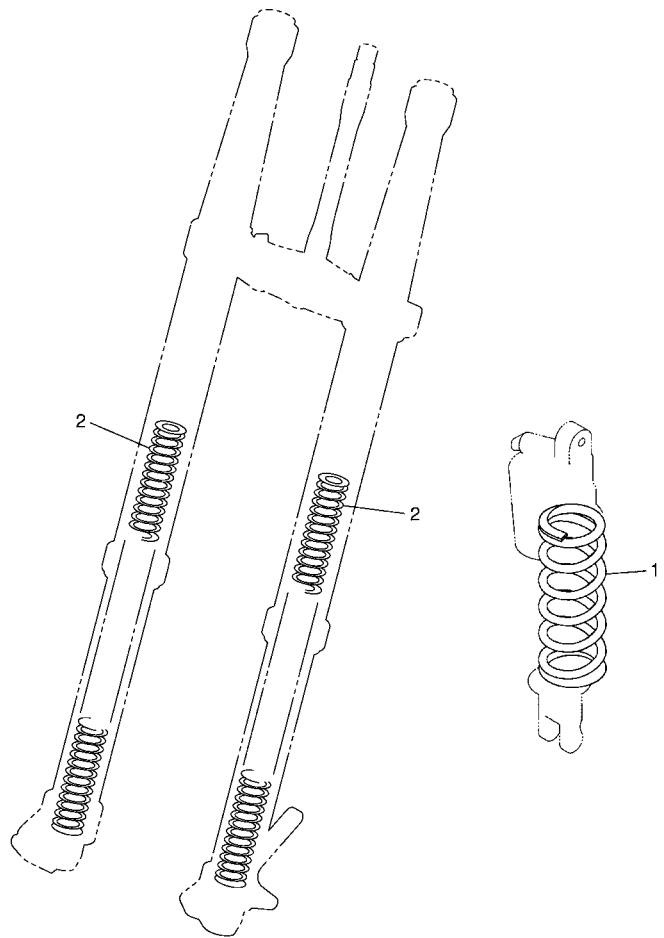

REF. NO.	PART NO.	DESCRIPTION	5XCR	5XCS	5XCT	5XCU	REMARKS
2	1C3-23141-J1	SPRING, FRONT FORK(K=4.7N/MM)	2	2	2	2	AP

5XC9100-E390

NUMERICAL INDEX

PART NO.	REF. NO.	PART NO.	REF. NO.	PART NO.	REF. NO.	PART NO.	REF. NO.	PART NO.	REF. NO.	PART NO.	REF. NO.
5XC-11102-20	1 - 1	1HX-12168-R1	3 - 14	5XC-13416-90	22 - 18	5JG-14531-00	10 - 60	5TA-14916-PU	10 - 12	5XC-15150-21-YX	13 - 1
5NL-11133-10	1 - 2	1HX-12168-U1	3 - 14	5D3-13440-00	8 - 1	3TJ-14536-40	10 - 32	5XC-14922-00	10 - 44	3Y1-15361-00	14 - 30
5NL-11134-10	1 - 3	1HX-12168-W1	3 - 14	5BE-13447-20	8 - 2	5JG-14546-01	10 - 10	3TJ-14933-40	10 - 33	3Y1-15363-00	14 - 6
5XC-11166-00	1 - 21	1HX-12168-Y1	3 - 14	5XC-13464-30	7 - 18	676-14548-00	10 - 25	5TA-14934-00	10 - 46	5XC-15373-00	14 - 16
371-11167-01	1 - 20	1HX-12169-11	3 - 14	5XC-13465-30	7 - 23	4MX-14561-00	10 - 50	5JG-14940-16	10 - 31	2S2-15378-00	14 - 29
5NL-11181-00	1 - 15	1HX-12169-31	3 - 14	5XC-13597-30	9 - 1	6H4-14561-00	10 - 34	5JG-14940-17	10 - 31	4JT-15381-01	13 - 16
5NL-11191-40	1 - 19	1HX-12169-50	3 - 14	5XC-14101-R0	10 - 1	5NX-14562-00	10 - 48	5JG-14940-18	10 - 31	5BE-15383-01	13 - 12
5NL-11193-00	1 - 24	1HX-12169-70	3 - 14	5XC-14101-S0	10 - 1	3TJ-14564-40	10 - 43	5JG-14940-76	10 - 31	5NL-15388-00	13 - 14
5UM-1119E-00	1 - 23	1HX-12169-90	3 - 14	5NL-14105-00	10 - 23	5JG-14565-00	10 - 59	5TA-14943-28	10 - 22	5NL-15411-30	14 - 1
5XC-11311-10	1 - 25	1HX-12169-E0	3 - 14	4MX-14115-00	10 - 51	5NL-14591-00	10 - 61	4MX-14943-41	10 - 18	5NL-15415-30	14 - 22
5NL-11351-00	1 - 26	1HX-12169-G0	3 - 14	3TJ-14137-40	9 - 8	688-14592-00	10 - 4	4MX-14943-42	10 - 18	5BE-15421-30	13 - 9
5XC-11400-20	2 - 1	1HX-12169-J0	3 - 14		10 - 52	5XC-14611-20	12 - 1	4MX-14943-43	10 - 18	5XC-15431-01	14 - 12
5UL-11412-20	2 - 2	1HX-12169-L0	3 - 14	5BE-14146-00	10 - 53	5XC-14611-R0	11 - 1	4MX-14943-44	10 - 18	5NL-15441-01	13 - 8
5UL-11422-10	2 - 3	1HX-12169-N0	3 - 14	5PA-14146-00	10 - 62	5NL-14613-00	11 - 5	4MX-14943-91	10 - 18	5NL-15451-00	14 - 8
5NL-11454-00	2 - 13	1HX-12169-T0	3 - 14	5TA-14155-00	10 - 40		12 - 6	4MX-14943-92	10 - 18	5NL-15453-10	14 - 27
5NL-11455-00	2 - 9	5UL-12170-10	4 - 1	633-14159-00	10 - 27	5XC-14628-00	12 - 2	4MX-14943-93	10 - 18	5NL-15462-00	14 - 17
5NL-11531-00	2 - 12	5UL-12180-10	4 - 2	3TJ-14159-40	10 - 13	5XC-14628-R0	11 - 2	4MX-14943-94	10 - 18	5NL-15601-20	15 - 1
5NL-11536-10	2 - 8	5TA-12210-20	4 - 10	5XC-14171-00	10 - 35	5XC-1466G-R0	11 - 7	4MX-14943-95	10 - 18	5XC-15620-10	15 - 19
5NL-11603-00	2 - 19	4FM-12213-00	4 - 9	3TJ-14191-40	10 - 29	5XC-1466G-S0	12 - 8	5XC-14947-00	10 - 17	5XC-15621-10	15 - 20
5XC-11631-00	2 - 18	5BE-12241-00	4 - 12	5UL-14196-00	10 - 55	5XC-1469A-10	12 - 10	4MX-14948-02	10 - 19	5NL-15641-20	15 - 2
5NL-11633-00	2 - 20	5NL-12251-10	4 - 5	5TA-14197-00	10 - 56	5XC-1469A-R0	11 - 9	4MX-14948-03	10 - 19	5NL-15651-00	15 - 16
5XC-11651-00	2 - 6	5NL-12252-00	4 - 6	5NX-14216-00	10 - 49	2S2-1469E-00	11 - 10	4MX-14948-04	10 - 19	5NL-15664-00	15 - 10
5XC-11681-00	2 - 4	5XC-1240A-G0	6 - 1	5TA-14227-00	9 - 5		12 - 11	4MX-14948-05	10 - 19	5SG-15668-00	15 - 12
5NL-12111-20	3 - 1	5NL-12422-10	5 - 9	5TA-14239-00	9 - 6	2S2-1469F-00	11 - 11	4MX-14948-06	10 - 19	2S2-15671-00	15 - 5
5NL-12112-20	3 - 2	5NL-12439-00	5 - 10	5TA-14261-00	10 - 54		12 - 12	4JT-1494F-03	10 - 21	214-15686-00	15 - 13
5NL-12113-00	3 - 8	5DH-12451-00	5 - 4	5JG-14264-00	10 - 16	5XD-14714-00	11 - 12	4JT-1494F-07	10 - 21	5NL-16111-01	16 - 1
5NL-12114-00	3 - 9	5XC-12459-00	5 - 1	3TJ-14267-40	10 - 9		12 - 13	4JT-1494F-11	10 - 21	5XC-16150-10	16 - 4
5NL-12116-00	3 - 4	5XC-12461-G0	6 - 5	5JG-14275-00	10 - 15	5BE-14747-00	11 - 13	3TJ-1494F-13	10 - 20	5XC-16154-00	16 - 5
1HX-12117-00	3 - 10	22W-12462-00	6 - 9	5TA-14293-00	9 - 4		12 - 14	3TJ-1494F-14	10 - 20	5XC-16181-00	16 - 12
1WG-12117-00	3 - 12	2S2-12464-70	6 - 2	3TJ-14293-40	10 - 30	5XC-14750-R0	11 - 6	3TJ-1494F-15	10 - 20	5XC-16321-00	16 - 7
1HX-12118-00	3 - 11		6 - 6	5XD-14325-00	10 - 63	5XC-14750-S0	12 - 7	4JT-1494F-15	10 - 21	5NL-16325-00	16 - 8
1WG-12118-00	3 - 13	5XC-12481-G0	6 - 12	5TA-14335-00	10 - 37	4BD-14766-00	12 - 3	3TJ-1494F-16	10 - 20	5HD-16351-00	16 - 9
4SV-12119-00	3 - 7	1C3-12482-00	6 - 16	5JG-14346-00	10 - 58	5BE-14788-00	11 - 15	3TJ-1494F-17	10 - 20	5XC-16356-00	16 - 16
4TV-12119-00	3 - 6	5Y9-12491-00	39 - 10	5TA-14371-00	10 - 36		12 - 16	3TJ-1494F-18	10 - 20	5NL-16357-10	16 - 21
5NL-12121-10	3 - 3		39 - 12	2S2-14374-00	10 - 39	5TA-14916-KR	10 - 12	3TJ-1494F-19	10 - 20	5NL-16371-30	16 - 6
3GM-12126-00	3 - 5	5NL-12564-00	14 - 20	5JG-14379-00	10 - 42	5TA-14916-L1	10 - 12	4JT-1494F-19	10 - 21	5XC-16381-00	16 - 22
3FV-12153-10	3 - 16	5XC-12576-G0	6 - 15	2S2-14388-00	10 - 8	5TA-14916-LN	10 - 12	4JT-1494F-23	10 - 21	4JT-16384-00	16 - 25
3LN-12153-10	3 - 15	5XC-12578-G0	6 - 17	4MX-14392-00	10 - 26	5TA-14916-LP	10 - 12	4JT-1494F-27	10 - 21	5NL-17121-00	17 - 9
1HX-12168-00	3 - 14	5XC-12579-G0	6 - 18	2S2-14401-70	9 - 11	5TA-14916-LR	10 - 12	5JG-14951-00	10 - 6	5NL-17131-10	17 - 6
1HX-12168-20	3 - 14	583-13113-00	8 - 20	5XC-14417-90	9 - 16	5TA-14916-LS	10 - 12	5JG-14959-00	10 - 2	5NL-17141-11	17 - 7
1HX-12168-40	3 - 14	5NL-13161-20	8 - 8	5NY-14442-00	9 - 15	5TA-14916-LT	10 - 12	5JG-14984-00	10 - 28	5NL-17151-00	17 - 3
1HX-12168-60	3 - 14	5NL-13171-00	8 - 13	4XM-14451-00	9 - 19	5TA-14916-LU	10 - 12	4SR-14985-00	10 - 24	5NL-17211-10	17 - 21
1HX-12168-80	3 - 14	5SG-13300-01	7 - 1	5XC-14453-R0	9 - 12	5TA-14916-P1	10 - 12	5TA-14987-00	9 - 7	5NL-17221-00	17 - 13
1HX-12168-A0	3 - 14	5NL-13320-00	7 - 3	5NY-14455-20	9 - 14	5TA-14916-PN	10 - 12	5JT-14987-00	10 - 57	5NL-17231-11	17 - 17
1HX-12168-F0	3 - 14	5NL-13341-00	7 - 11	5BE-14458-00	9 - 22	5TA-14916-PP	10 - 12	5TA-14991-00	10 - 38	5NL-17241-11	17 - 16
1HX-12168-H1	3 - 14	5BE-13342-00	7 - 10	5NY-14459-00	9 - 13	5TA-14916-PR	10 - 12	4FN-14997-00	10 - 11	5NL-17251-10	17 - 20
1HX-12168-K1	3 - 14	5NL-13411-00	7 - 16	5JG-14521-00	10 - 14	5TA-14916-PS	10 - 12	5TA-14997-00	10 - 41	5NL-17402-00	17 - 12
1HX-12168-M1	3 - 14	5XC-13412-00	7 - 15	5JG-14522-00	10 - 7	5TA-14916-PT	10 - 12	5XC-15118-00	14 - 31	5XC-17411-00	17 - 1

NUMERICAL INDEX

PART NO.	REF. NO.	PART NO.	REF. NO.	PART NO.	REF. NO.	PART NO.	REF. NO.	PART NO.	REF. NO.	PART NO.	REF. NO.
5NL-17466-00	13 - 11	3WF-2153E-40	21 - 17	5XC-22201-80	24 - 2	5XC-23111-00	26 - 21	5XE-23171-L0	26 - 4	34P-24710-00	28 - 1
5NL-17471-10	17 - 29	5RU-21568-01	21 - 22	5XC-22201-90	24 - 2		26 - 45		26 - 28	34P-24710-10	28 - 1
5UL-18101-10	19 - 10	2S2-21610-70	21 - 8	5XC-22201-Y0	24 - 2	276-23114-00	26 - 23	5DH-23183-00	24 - 7	34P-24710-20	28 - 1
5XC-18110-10	19 - 15	5XC-21610-90	21 - 8	1C3-22212-00	40 - 1		26 - 47	509-23184-L0	24 - 5	34P-24710-30	28 - 1
5LP-18122-01	19 - 5	5XE-21635-10	21 - 9	5UN-22212-00	40 - 1	5XC-23120-N0	26 - 3	1C3-23188-L0	26 - 13	5NY-25104-00	29 - 6
3XK-18140-00	18 - 8	5TA-21642-00	21 - 15	1C3-22212-10	40 - 1	5XE-23125-L0	26 - 5		26 - 37	5NY-25111-00	29 - 1
5BE-18172-00	19 - 3	3RV-21668-A0	23 - 32	5UN-22212-10	40 - 1		26 - 29	1C3-23188-N0	26 - 14	5NY-25117-00	29 - 3
3XJ-18173-10	19 - 2	3RV-21668-B0	23 - 33	1C3-22212-20	40 - 1	5XC-23136-00	26 - 2		26 - 38	5XC-25181-G0	29 - 11
3XJ-18178-00	19 - 9	34P-2167A-00	22 - 2	5UN-22212-20	40 - 1		26 - 26	1C3-23188-P0	26 - 15	5XC-25183-G0	29 - 12
3XJ-18182-00	19 - 8	34P-2167A-10	22 - 2	1C3-22212-30	40 - 1	1C3-23141-A1	40 - 2		26 - 39	5XC-25186-G0	29 - 13
3XJ-18184-00	19 - 7	34P-2167B-00	22 - 6	5UN-22212-30	40 - 1	1C3-23141-B1	40 - 2	1C3-23188-R0	26 - 16	34P-25304-00	31 - 7
2S2-18185-00	19 - 1	34P-2167B-10	22 - 6	1C3-22212-40	40 - 1	1C3-23141-C1	40 - 2		26 - 40	17D-2530S-00	31 - 18
5NL-18501-00	18 - 5	5XC-21710-90	22 - 1	5UN-22212-40	40 - 1	1C3-23141-D1	40 - 2	1C3-23190-L0	26 - 18	17D-25311-00	31 - 1
5NL-18502-00	18 - 6	5XC-21720-90	22 - 5	1C3-22212-50	40 - 1	1C3-23141-E1	40 - 2		26 - 42	17D-25317-00	31 - 2
5NL-18503-00	18 - 7	2S2-2172A-70	22 - 12	5UN-22212-50	24 - 17	1C3-23141-H1	40 - 2	5XC-23340-P0	26 - 49	4XM-25364-00	31 - 12
5NL-18541-00	18 - 1	2S2-2172A-80	22 - 16	1C3-22212-60	40 - 1	1C3-23141-J1	40 - 2	5XE-23389-00	25 - 15	17D-25381-00	31 - 23
4UN-18542-00	18 - 4	2S2-21730-70	22 - 9	5UN-22212-60	40 - 1	2S2-23141-M1	26 - 20	4EW-23416-00	25 - 2	17D-25388-00	31 - 19
5DH-18562-00	13 - 18	5XC-21730-90	22 - 9	5UN-22212-70	40 - 1		26 - 44	17D-23435-00	25 - 5	17D-25389-00	31 - 20
5XC-21101-R1	20 - 1	34P-2173L-10	22 - 10	5UN-22212-A0	40 - 1	5XC-23141-N0	26 - 20	5XC-23441-90	25 - 8	4XM-25394-00	31 - 11
5XC-21163-90	20 - 45	5XC-2173L-40	22 - 10	5UN-22212-B0	40 - 1		26 - 44	5UM-23442-E0	25 - 9	5SF-25394-00	29 - 10
5XC-21164-90	20 - 46	2S2-21740-70	22 - 13	5UN-22212-C0	40 - 1	1C3-23142-L0	26 - 19	17D-23466-00	26 - 57	1C3-25447-00	31 - 13
5PA-2118K-00	21 - 18	5XC-21740-90	22 - 13	5UN-22212-D0	40 - 1		26 - 43	17D-23467-00	26 - 58	1C3-25448-00	31 - 13
5PA-2118K-10	21 - 19	34P-2174L-10	22 - 14	5UN-22212-E0	40 - 1	5XE-23144-L0	26 - 9	1C3-23485-61	25 - 13	1C3-25449-00	31 - 13
5PA-2118K-20	21 - 18	5XC-2174L-40	22 - 14	5UN-22212-F0	40 - 1		26 - 33	2S2-24110-70	27 - 1	1C3-25450-00	31 - 13
5XC-21190-L0	20 - 5	5XC-21751-G0	22 - 17	5UN-22212-G0	40 - 1	1C3-23145-M0	26 - 7	4EW-2412F-00	27 - 19	1C3-25451-00	31 - 13
1C3-21244-10	20 - 32	17D-22110-00	23 - 1	5UN-22212-K0	24 - 17		26 - 31	5XE-24144-00	27 - 6	1C3-25452-00	31 - 13
5XC-21274-90	20 - 43	5XC-22121-91	23 - 28	1C3-22213-L0	24 - 4	5XC-23146-10	26 - 6	3ME-2415E-01	21 - 23	5CG-25715-00	34 - 9
5XC-21288-90	20 - 48	34P-22122-00	23 - 29	1C3-22214-50	24 - 18		26 - 30	3FB-2415E-02	21 - 5		36 - 9
5XC-21417-G0	20 - 33	2S2-22128-70	23 - 11	5MV-22224-00	24 - 9	1AE-23147-00	26 - 17	3FB-2415E-12	21 - 6	1C3-25718-50	32 - 19
5XC-21418-G0	20 - 34	1C3-22141-10	23 - 15	4JX-22226-00	24 - 6		26 - 41	3FB-2415E-C1	21 - 5	5XC-2580T-G0	30 - 3
5XC-21425-G0	20 - 23	34P-22151-00	23 - 8	3SP-22234-00	24 - 3	1C3-23147-L0	26 - 11	4SR-2416E-00	21 - 7	17D-2580W-01	32 - 3
5XC-21426-G0	20 - 24	5UN-22176-00	24 - 13	5NY-22241-00	24 - 22		26 - 35	5XC-24181-90	27 - 21	17D-2580W-11	32 - 3
1C3-21447-10	20 - 2	30X-22178-00	20 - 8	5XE-22242-00	24 - 19	5XC-2314F-00	26 - 24	5XC-24182-90	27 - 31	5XC-2581T-G0	30 - 1
1C3-21448-10	20 - 3	3JD-22178-20	20 - 13	1C3-22253-50	24 - 10		26 - 48	5XC-24183-90	27 - 32	1UY-25824-51	32 - 7
5XC-21456-90	20 - 37	17D-2217A-00	23 - 18	1C3-22253-L0	24 - 15	5XE-23153-L0	26 - 8	3JD-24186-00	27 - 11	1UY-25825-51	32 - 8
5XC-21471-90	20 - 38	17D-2217F-00	23 - 24	4AA-22259-40	24 - 8		26 - 32	5UM-2419A-E0	27 - 12	5UN-25827-60	32 - 11
5XC-2147E-G0	20 - 40	4V4-22184-00	20 - 9	4AA-22259-50	24 - 8	2HH-23158-L0	26 - 22	5XC-24311-G0	27 - 27	5UN-25828-60	32 - 10
5XC-21486-90	20 - 42	5MV-22184-00	24 - 14	4AA-22259-60	24 - 8		26 - 46	5XC-24339-90	27 - 14	2S2-2582W-70	32 - 1
1C3-21511-51	21 - 1	2S2-22199-70	23 - 10	4EW-22474-00	24 - 12	5XC-2315H-00	26 - 52	3XJ-24380-00	27 - 4	5MV-25833-00	34 - 16
2S2-21511-70	21 - 1	5XC-22200-30	24 - 1	3JE-22475-00	24 - 11	5XC-2315J-00	26 - 54	4JT-24500-10	27 - 22	17D-2583V-00	36 - 1
4LB-2151H-A2	21 - 20	5XC-22200-40	24 - 1	5NY-22475-00	24 - 16	5XC-2316A-V0	26 - 12	4X8-24512-00	27 - 25	5XC-25849-G0	30 - 15
3XJ-2151H-A1	21 - 20	5XC-22200-60	24 - 1	5UN-22898-60	32 - 12		26 - 36	3AC-24523-00	27 - 26	5UN-25852-50	36 - 5
3XJ-2151H-B1	21 - 21	5XC-22200-80	24 - 1	1C3-22969-90	23 - 9	5XC-2316A-W0	26 - 12	3AJ-24534-01	27 - 23	5XC-25852-G0	34 - 7
4XL-2153A-10	26 - 53	5XC-22200-90	24 - 1	5XC-23102-R0	26 - 1		26 - 36	5NY-24610-00	27 - 2	5XC-25853-G0	34 - 10
	26 - 55	5XC-22200-Y0	24 - 1	5XC-23102-S0	26 - 10	5XC-23170-R0	26 - 10	34P-2470F-00	28 - 2	5UN-25854-00	36 - 7
4ES-2153E-01	21 - 4	5XC-22201-30	24 - 2	5XC-23103-R0	26 - 25		26 - 34	34P-2470F-10	28 - 2	5XC-25854-G0	34 - 6
3WF-2153E-10	21 - 17	5XC-22201-40	24 - 2	5XC-23103-S0	26 - 25	5XC-23170-S0	26 - 10	34P-2470F-20	28 - 2	5UN-2585B-00	36 - 6
4ES-2153E-20	21 - 4	5XC-22201-60	24 - 2	5XC-23110-N0	26 - 27		26 - 34	34P-2470F-30	28 - 2	5CG-2585G-00	34 - 11

NUMERICAL INDEX

PART NO.	REF. NO.	PART NO.	REF. NO.	PART NO.	REF. NO.	PART NO.	REF. NO.	PART NO.	REF. NO.	PART NO.	REF. NO.
5CG-2585G-00	36 - 10	1C3-27491-50	32 - 21	90105-06104	23 - 12	90119-06151	25 - 14	90201-08048	15 - 25	90340-32006	14 - 2
5MV-25867-00	34 - 15	5XC-28116-00	20 - 52	90105-06105	23 - 14	90119-08095	22 - 4		31 - 16	90387-06009	21 - 14
5XC-25872-L0	34 - 1	5TA-2814F-00	20 - 51	90105-06106	21 - 12		22 - 8	90201-08061	11 - 16	90387-06065	6 - 23
5XC-25873-L0	36 - 12	5ET-28166-10	20 - 50	90105-06107	25 - 16	90122-06005	9 - 21		12 - 17		27 - 18
1C3-25876-50	36 - 17	5UL-82310-10	39 - 3		27 - 8	90149-05162	38 - 16	90201-080H1	16 - 18	90387-06090	21 - 2
1C3-25886-50	36 - 15	5XC-82509-00	39 - 14		27 - 15	90149-06074	13 - 17	90201-082A6	22 - 22		27 - 13
5MV-2589F-00	34 - 13	5XC-82540-00	39 - 4		32 - 22	90149-06084	2 - 14	90201-08410	10 - 45	90387-06104	25 - 17
5UN-25914-00	32 - 17	17D-82911-00	38 - 1	90105-06110	32 - 20	90149-06108	27 - 30	90201-08512	5 - 2	90387-06150	22 - 26
5DH-25914-50	32 - 15	17D-82913-00	38 - 10	90105-06111	6 - 24	90149-06121	37 - 3		5 - 5	90387-06161	22 - 30
3SP-25914-51	30 - 12	5XD-82946-00	38 - 9		27 - 9	90149-10031	20 - 4	90201-096J9	1 - 18	90387-08041	20 - 11
5DH-25916-00	30 - 10	17D-83912-00	38 - 2		27 - 16	90151-06032	20 - 44	90201-10032	35 - 16	90387-08081	11 - 14
	32 - 14	5XC-83922-L0	34 - 12		32 - 23	90151-06044	13 - 13	90201-10045	20 - 21		12 - 15
3JD-25917-00	30 - 13	5TA-83941-00	38 - 11	90105-06112	22 - 28	90151-06051	30 - 2		20 - 27	90387-086N4	20 - 15
	32 - 16	1C3-83976-00	38 - 18	90105-06128	22 - 23	90152-06010	15 - 23		20 - 31	90387-124F4	19 - 11
5DH-25919-00	30 - 6	5LP-84126-10	38 - 4	90105-06156	32 - 2	90154-05022	39 - 6	90201-12166	7 - 13	90387-14016	23 - 27
5DH-25919-50	32 - 6	5XC-85540-R0	39 - 1	90105-06178	26 - 59	90159-06049	16 - 11	90201-127E1	37 - 5	90387-16026	23 - 21
8CR-25924-00	32 - 13	5XC-85540-S0	39 - 1	90105-08137	11 - 17	90170-14171	2 - 16	90201-14020	23 - 30	90387-18004	23 - 7
3SP-25926-51	30 - 11	1C3-85546-00	39 - 2		12 - 18	90170-16326	16 - 15	90201-15701	14 - 14	90387-18007	13 - 22
5DH-25933-00	30 - 9	5TA-85550-00	37 - 2		30 - 16	90170-24003	25 - 6	90201-16018	23 - 17	90387-18012	23 - 6
1UY-25937-51	30 - 14	5XC-85560-10	37 - 1	90105-08143	20 - 35	90179-06028	23 - 13	90201-162H4	15 - 11	90387-20006	17 - 8
	32 - 18	5XC-85885-00	10 - 47	90105-08146	20 - 16	90179-08019	31 - 22	90201-167P7	15 - 7	90387-22001	17 - 24
5XC-26111-L0	33 - 1	5XC-W0041-00	34 - 5	90105-08147	20 - 26	90179-10658	20 - 20	90201-177G4	15 - 17	90387-225N2	33 - 12
17D-26124-00	33 - 14	5UN-W0042-50	36 - 2	90105-08150	20 - 22		20 - 30	90201-20685	15 - 3	90401-08006	8 - 11
5XC-26143-L0	33 - 15	5XC-W0045-00	30 - 8	90105-08151	22 - 21	90179-12657	37 - 4	90201-21014	23 - 23	90401-10015	8 - 9
5XC-26143-M0	33 - 15	1C3-W0046-50	32 - 9	90105-08154	25 - 12	90179-16011	29 - 14	90201-22013	16 - 13	90401-10172	34 - 3
5TJ-26240-C0	33 - 3	1C3-W0046-B0	32 - 9		26 - 51	90179-18001	16 - 3	90201-22021	31 - 25		36 - 13
4GY-26241-00	33 - 2	5KM-W0047-10	30 - 5	90105-08156	20 - 6		17 - 28	90201-24016	25 - 7	90430-06014	1 - 10
4GY-26242-00	33 - 4	5UN-W0047-50	32 - 5	90105-08307	11 - 18	90179-28013	25 - 3	90201-286K9	25 - 4	90430-08119	8 - 12
3Y1-26249-00	33 - 5	1UY-W0048-50	30 - 7		12 - 19	90183-060A6	6 - 4	90202-05193	27 - 29	90430-10005	34 - 2
5BE-26281-00	33 - 6	5XC-W0057-00	30 - 4		20 - 7		6 - 8	90202-08045	10 - 5		36 - 14
5BE-26282-00	33 - 7	5UN-W0057-50	32 - 4	90105-09002	1 - 17	90185-08008	31 - 15	90206-06090	12 - 5		8 - 10
5SF-26287-10	33 - 9	5XC-W2587-00	34 - 4	90105-09004	1 - 16	90185-08009	20 - 17	90209-06096	9 - 20	90430-10188	13 - 7
5XC-26302-R0	33 - 10	90101-05005	38 - 7	90105-10174	20 - 19	90185-10012	24 - 23	90209-16011	23 - 22		27 - 3
5XC-26334-R0	38 - 12	90101-06041	19 - 4	90105-10176	20 - 29	90185-14010	23 - 31	90209-20008	17 - 4	90445-09220	27 - 5
5XC-26335-R0	33 - 11	90101-06044	15 - 14	90105-10191	20 - 25	90185-16002	23 - 16		17 - 18	90445-09251	7 - 29
17D-26337-00	38 - 5	90101-08006	31 - 21	90109-06034	38 - 3	90185-22009	31 - 24	90209-23012	17 - 14	90445-14010	7 - 30
5TA-26339-00	38 - 17	90105-05014	20 - 49	90109-06193	18 - 10	90201-03313	9 - 18	90215-14204	2 - 15	90450-17001	6 - 20
34P-26342-00	33 - 13	90105-06027	1 - 7	90109-06232	26 - 56	90201-05017	11 - 3	90215-16289	16 - 14	90450-22001	7 - 22
34P-26372-00	38 - 8	90105-06064	22 - 11	90109-06245	9 - 23	90201-06085	21 - 13	90215-20003	16 - 2		6 - 19
5XC-26372-G0	34 - 17		22 - 15	90109-08078	31 - 14	90201-06104	21 - 11		17 - 27	90450-25001	6 - 21
5XC-27200-A0	35 - 1	90105-06081	13 - 15	90110-05038	9 - 9	90201-06570	27 - 10	90240-08120	35 - 6	90450-32003	9 - 3
5UN-27217-00	36 - 8		13 - 19	90110-06228	8 - 5		27 - 17	90267-32070	35 - 11	90450-57010	9 - 10
5XC-27217-90	35 - 2		17 - 30	90110-08051	15 - 26	90201-06571	6 - 25	90267-48084	9 - 17	90464-06004	39 - 13
5UN-27218-00	36 - 3	90105-06094	14 - 32	90111-06116	36 - 11		22 - 27		11 - 8	90464-13073	39 - 8
5UN-27222-00	36 - 4	90105-06098	14 - 25	90116-06038	1 - 11	90201-06630	22 - 24		12 - 9	90464-13077	39 - 7
34P-27311-00	35 - 15	90105-06100	21 - 10	90119-06146	20 - 39	90201-08043	20 - 18	90280-03006	2 - 11	90464-15195	39 - 9
5XC-27411-M1	35 - 9	90105-06103	22 - 3		20 - 41	90201-08044	35 - 7	90340-12007	1 - 8	90465-08029	14 - 28
5XC-27421-M1	35 - 10		22 - 7	90119-06147	21 - 3	90201-08045	20 - 10	90340-14015	14 - 4		

NUMERICAL INDEX

PART NO.	REF. NO.	PART NO.	REF. NO.	PART NO.	REF. NO.	PART NO.	REF. NO.	PART NO.	REF. NO.	PART NO.	REF. NO.
90465-10013	13 - 24	92902-10200	25 - 10	93315-32166	23 - 25	95022-06020	19 - 16	9Y582-28111	31 - 26		
90465-13275	27 - 33	93101-14164	14 - 13	93317-11287	16 - 23		38 - 13	9Y582-28113	31 - 26		
	39 - 11	93102-12106	5 - 7	93317-22262	23 - 2	95022-06025	4 - 11				
90467-090A2	6 - 11	93102-12224	16 - 24	93332-00068	25 - 1		5 - 13				
90467-100A1	27 - 28		19 - 14	93332-00081	26 - 50		7 - 17				
90467-140A4	1 - 22	93102-18278	15 - 15	93340-21008	16 - 17		7 - 21				
90468-16001	35 - 8	93102-26468	29 - 4	93342-22217	23 - 3		7 - 24				
90480-08608	31 - 17	93102-28010	17 - 25	93410-20038	15 - 4		14 - 11				
90480-10289	22 - 25	93102-32337	31 - 4	93410-22039	17 - 5		14 - 23				
90480-14433	22 - 29	93106-22002	23 - 4		17 - 19	95022-06035	1 - 29				
90480-15528	6 - 22	93109-11073	5 - 6	93410-26067	17 - 15		14 - 10				
90480-18549	27 - 7	93109-21001	23 - 26	93420-16086	2 - 21		14 - 19				
90501-043E0	8 - 18	93109-25001	23 - 20	93440-07149	1 - 5		14 - 24				
90501-052G5	19 - 6	93109-28043	23 - 5	93440-07182	5 - 3	95022-06065	5 - 14				
90501-06022	18 - 3	93210-07003	8 - 14		16 - 19	95022-08040	20 - 12				
90501-147A5	15 - 21	93210-07135	8 - 4	93440-10153	1 - 4	95022-10016	13 - 6				
90501-160A2	15 - 6	93210-09008	8 - 15		7 - 4	95302-05700	38 - 6				
90501-230A2	16 - 10	93210-09754	7 - 28	93440-41178	4 - 3	95602-05100	38 - 15				
90506-16007	35 - 5	93210-10197	7 - 8	93503-08007	8 - 19	95602-10200	24 - 20				
90508-26561	18 - 9		7 - 19	93507-32009	15 - 22		25 - 11				
90508-28015	35 - 13		7 - 25	93511-32027	16 - 20	95612-08620	1 - 12				
90508-28018	35 - 14		13 - 20	93603-16219	7 - 2	95701-06500	34 - 14				
90508-291A8	19 - 12	93210-11073	35 - 3	93604-10011	5 - 11	95702-06500	1 - 27				
90508-30743	15 - 9	93210-12759	8 - 16	93608-33002	19 - 13	95702-08500	1 - 13				
91312-06016	22 - 20	93210-14369	14 - 5	93612-16254	1 - 28	97022-06016	4 - 7				
91312-06020	6 - 13		22 - 19		13 - 2	97702-60016	21 - 16				
91312-06025	7 - 6	93210-16275	6 - 14	9383B-13218	17 - 26	98502-03008	27 - 24				
	8 - 7	93210-16716	14 - 21	94108-21027	29 - 7	98502-05010	36 - 16				
	9 - 2	93210-17570	15 - 24	94110-19019	31 - 8	98502-05020	33 - 8				
91312-06045	13 - 3	93210-19123	14 - 7	94209-21229	29 - 8	98502-06025	13 - 10				
91312-06055	13 - 4	93210-196A4	17 - 23	94210-19222	31 - 9	98702-06025	27 - 20				
91312-06065	8 - 6	93210-21001	39 - 5	94316-19156	31 - 10	98706-04012	34 - 8				
91312-06070	13 - 5	93210-32172	14 - 3	94330-21084	29 - 9	98980-06008	11 - 4				
91316-04012	10 - 3	93210-47675	8 - 3	94416-21034	29 - 5		12 - 4				
91317-06030	7 - 7	93300-60839	20 - 14	94416-21041	29 - 5	99001-08600	7 - 12				
91402-20012	35 - 4	93306-00105	5 - 8	94418-19026	31 - 6	99009-12400	7 - 14				
91402-25015	35 - 12	93306-00317	17 - 22	94418-19035	31 - 6	99009-16400	15 - 8				
91808-16023	1 - 6	93306-00320	17 - 10	94591-53114	4 - 4	99009-17400	15 - 18				
91812-16001	14 - 18	93306-20335	2 - 10	94682-28001	31 - 27	99009-22500	14 - 15				
91A20-05065	6 - 10	93306-20447	17 - 2	94701-00410	1 - 14	99009-42700	31 - 5				
92012-05008	20 - 47	93306-20648	2 - 7	94701-00411	1 - 14	99530-08012	7 - 5				
92012-05012	38 - 14	93306-27208	17 - 11	94703-00410	1 - 14	99530-08016	14 - 9				
92012-06010	6 - 3	93306-90409	29 - 2	94703-00411	1 - 14		14 - 26				
	6 - 7	93306-90509	18 - 2	95022-06010	1 - 9	99530-10114	7 - 9				
92902-06600	4 - 8	93306-90510	31 - 3		16 - 26		7 - 20				
92902-08200	20 - 28	93310-63238	2 - 5	95022-06012	5 - 15		7 - 26				
	20 - 36	93311-32261	2 - 17		8 - 17		13 - 21				
92902-10200	24 - 21	93315-32166	23 - 19	95022-06016	7 - 27	99530-10116	13 - 23				